



www.weka-holzbau.com



MASSIVHOLZ - HAUS



262.2121.10000
262.2121.10005
262.2121.16000
262.2121.16005



262.2121.10010
262.2121.10015
262.2121.16010
262.2121.16015



262.2121.10020
262.2121.10025
262.2121.16020
262.2121.16025



262.2121.10030
262.2121.10035
262.2121.16030
262.2121.16035

Montageanleitung

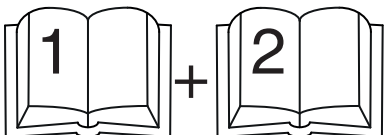

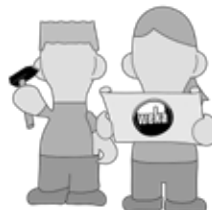

=



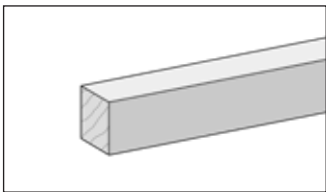
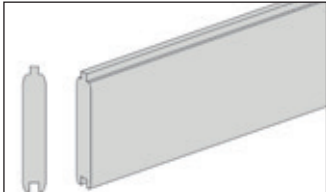
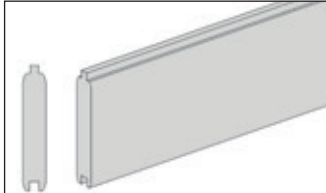
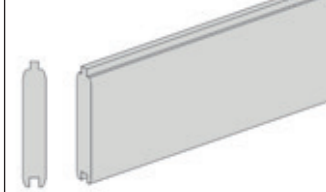
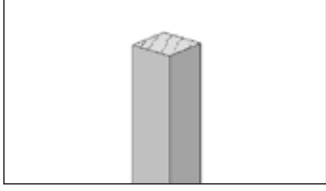

800.0286.17.72 800.0286.20.02

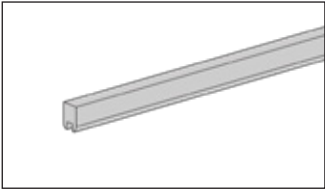
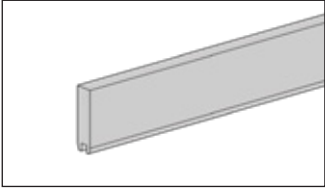
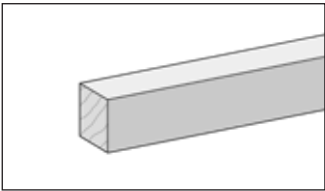
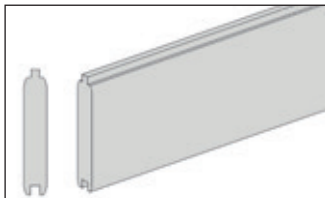
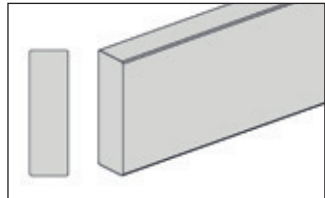
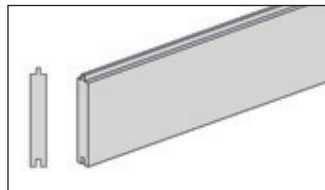

Stand: 2051

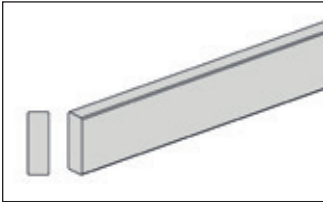
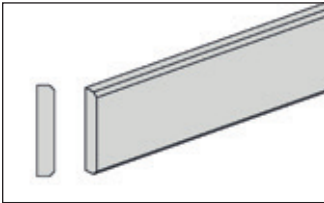
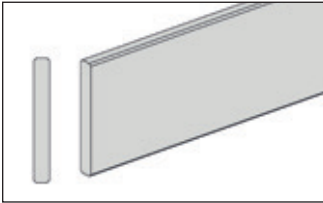
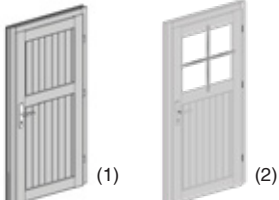
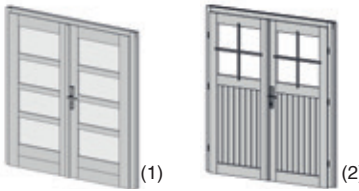



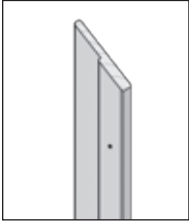
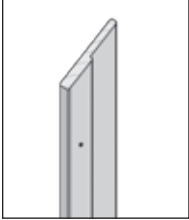
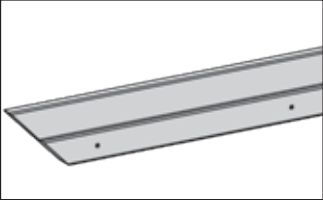
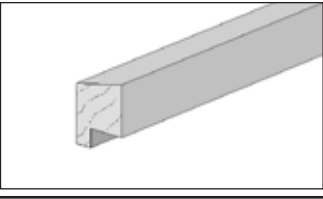
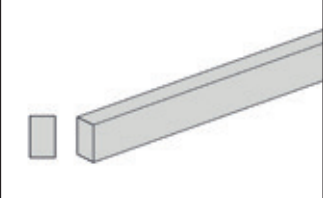
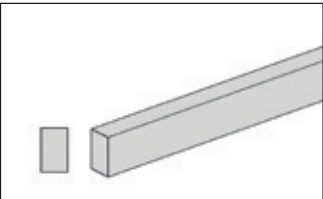

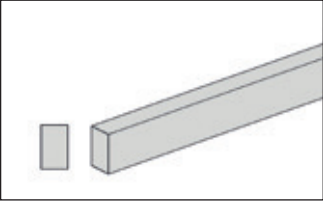
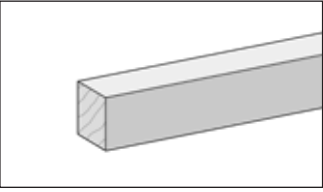
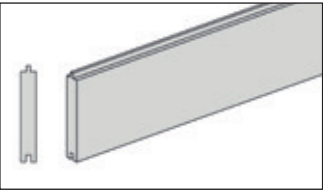
Pos	Bild	Abmessung (mm)	Anzahl (Stück)							
			262.2121.1X000	262.2121.1X020	262.2121.1X005	262.2121.1X025	262.2121.1X010	262.2121.1X030	262.2121.1X015	262.2121.1X035
①	R002.0660.2050 	40/40/2050	4	4	4	4	4	4	4	4
②	R002.0015.2050 R212.0015.2050 	21/121/2050	38	38	38	38	38	38	38	38
③	R002.0015.1750 R212.0015.1750 	21/121/1750	18	18	18	18	18	18	18	18
④	R002.0015.0130 R212.0015.0130 R002.0015.0560 R212.0015.0560 	21/121/130 21/121/560	- 32	32 -	- 32	32 -	32 -	32 -	- 32	32 -
⑤	R002.0196.2100 	34/34/2100	8	8	8	8	8	8	8	8
⑥	G227.01.0407 G227.212.0407 G227.212.0408 	21/81/2050	2	2	2	2	2	2	2	2



Pos	Bild	Abmessung (mm)	Anzahl (Stück)							
			262.2121.1X000	262.2121.1X020	262.2121.1X005	262.2121.1X025	262.2121.1X010	262.2121.1X030	262.2121.1X015	262.2121.1X035
7	G227.01.0410 G227.212.0410 	21/30/2050	1	1	1	1	1	1	1	1
8	G227.01.0409 G227.212.0409 	21/73/2050	1	1	1	1	1	1	1	1
9	R002.0225.2128 	40/40/2128	2	2	2	2	2	2	2	2
10	R002.0015.0295 R212.0015.0295 	21/121/295	36	36	36	36	36	36	36	36
11	R002.0350.2050 	45/146/2050	2	2	2	2	2	2	2	2
12	R002.0091.2100 	15,5/96/2100	24	24	24	24	24	24	24	24





Pos	Bild	Abmessung (mm)	Anzahl (Stück)							
			262.2121.1X000	262.2121.1X020	262.2121.1X005	262.2121.1X025	262.2121.1X010	262.2121.1X030	262.2121.1X015	262.2121.1X035
13	R002.0530.1360 	15/45/1360	2	2	2	2	2	2	2	2
14	R002.0400.2040 	11/58/2040	13	13	13	13	13	13	13	13
15	R002.0560.2135 	18,5/146/2135	4	4	4	4	4	4	4	4
16	B100.12.6230 B100.12.2330 B100.12.6270 B100.12.2370 	(1)60/965/1810 (2)60/965/1810	-	-	-	-	1	-	1	-
17	A100.12.5430 A100.12.2930 A100.12.5470 A100.12.2970 	(1)62/1820/1810 (2)62/1820/1810	-	-	-	-	-	1	-	1
18		19/650/650	1	2	1	2	-	-	-	-









Pos	Bild	Abmessung (mm)	Anzahl (Stück)							
			262.2121.1X000	262.2121.1X020	262.2121.1X005	262.2121.1X025	262.2121.1X010	262.2121.1X030	262.2121.1X015	262.2121.1X035
19	E100.12.0001 E100.12.0002 	18,5/70/1815	1	1	1	1	1	1	1	1
20	E100.12.0001 E100.12.0002 	18,5/70/1815	1	1	1	1	1	1	1	1
21	E100.12.0001 E100.12.0002 	18,5/70/965 18,5/70/1820	1 -	- 1	1 -	- 1	1 -	- 1	1 -	- 1
22	B100.03.0060 B100.03.0062 	35/60/990 35/60/1850	1 -	- 1	1 -	- 1	1 -	- 1	1 -	- 1
23	R002.0500.0990 	15/25/990 15/25/1850	1 -	- 1	1 -	- 1	1 -	- 1	1 -	- 1
24	G122.01.0003 	15/21/1805	2	3	2	3	2	3	2	3

Pos	Bild	Abmessung (mm)	Anzahl (Stück)							
			262.2121.1X000	262.2121.1X020	262.2121.1X005	262.2121.1X025	262.2121.1X010	262.2121.1X030	262.2121.1X015	262.2121.1X035
25	G122.01.0220 	15/21/910	1	-	1	-	1	-	1	-
26	R002.0660.2050 	40/40/1978	4	4	-	-	4	4	-	-
27	R002.0091.2100 	15,5/96/2050	24	24	-	-	24	24	-	-
28	G100.01.0040 G100.01.1040 	15/45/1768	-	1	-	1	-	1	-	1
29	K127.1590.0001 K127.1517.0001 	5/15/895 5/15/1750	1 -	- 1	1 -	- 1	1 -	- 1	1 -	- 1
-	-	-			-	-			-	-

Pos	Bild	Abmes- sung (mm)	Anzahl (Stück)							
			262.2121.1X000	262.2121.1X020	262.2121.1X005	262.2121.1X025	262.2121.1X010	262.2121.1X030	262.2121.1X015	262.2121.1X035
M1	K001.8050.0004 	5,0 X 80	5	5	5	5	5	5	5	5
M2	K001.6040.0004 	4,0 x 60	50	50	50	50	50	50	50	50
M3	K001.4040.0004 	4,0 x 40	530	530	530	530	530	530	530	530
M4	K001.3035.0004 	3,5 x 30	100	100	100	100	100	100	100	100
M5	K002.2050.0004 	5,0 x 20	150	150	150	150	150	150	150	150
M6	K010.5022.0001 	2,2 x 55	550	550	550	550	550	550	550	550

Pos	Bild	Abmessung (mm)	Anzahl (Stück)							
M7	K031.5050.0001 	50 x 50 x 40	6	6	6	6	6	6	6	6
M8	K074.4513.0000 		4	4	4	4	4	4	4	4
-	-	-	-	-	-	-	-	-	-	-

Pos	Bild	Abmessung (mm)	Anzahl (Stück)
M10	K001.4040.0004 	4,0 x 40	26
M11	K010.3016.0001 	1,6 x 30	4
M12	K036.3135.0001 		1
M13	K045.1270.0001 		1

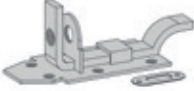
Pos	Bild	Abmessung (mm)	Anzahl (Stück)
M14	K001.6040.0004 	4,0 x 60	10
M15	K001.4040.0004 	4,0 x 40	20
M16	K001.3535.0004 	3,5 x 35	7
M17	K001.3030.0004 	3,0 x 30	4
M18	K001.1635.0004 	3,5 x 16	16
M19	K010.3016.0001 	1,6 x 30	16
M20	K045.1270.0001 		1
M21	K036.3135.0001 		1
M22	K050.5010.0001 	50 x 100	2

Art.-Nr.: 262.2121.1x000x
Art.-Nr.: 262.2121.1x001x

FW

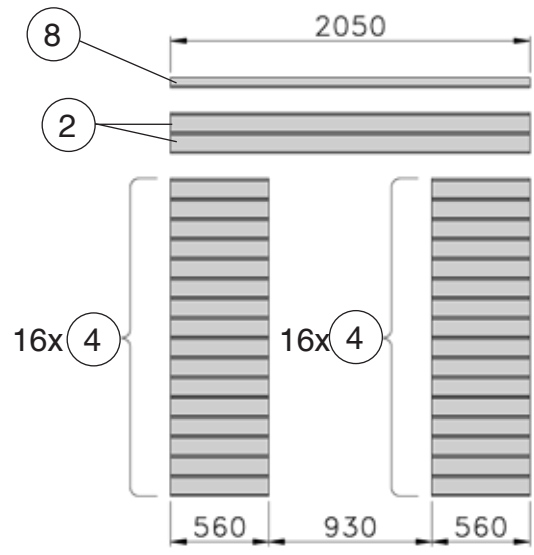

SW

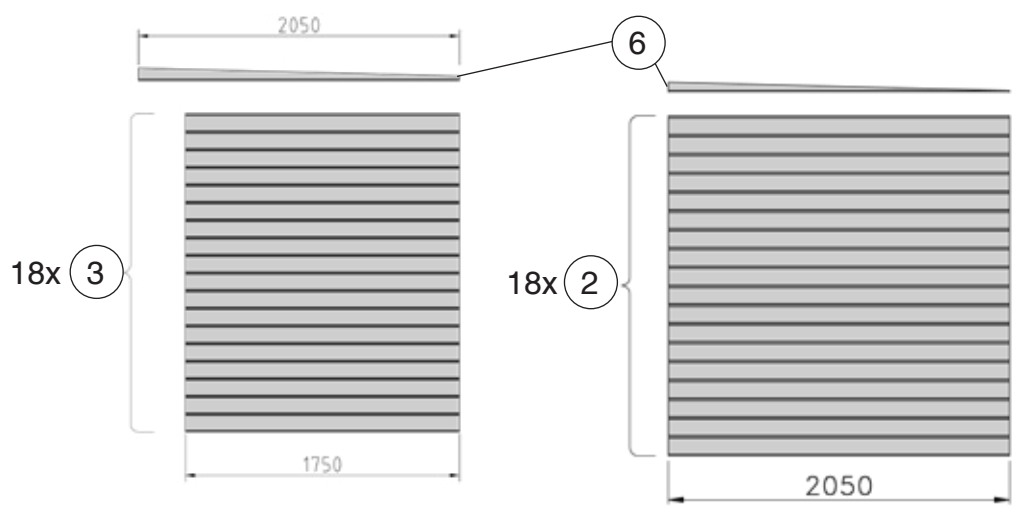

RW

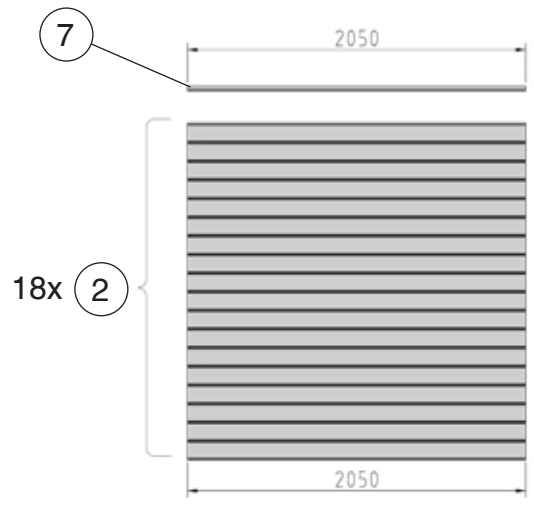

Angaben in mm

Pos	Abmessung	Stück
②	21/121/2050	38
③	21/121/1750	18
④	21/121/560	32
⑥	21/81/2050	2
⑦	21/30/2050	1
⑧	21/73/2050	1

Art.-Nr.: 262.2121.1x002x
Art.-Nr.: 262.2121.1x003x

FW

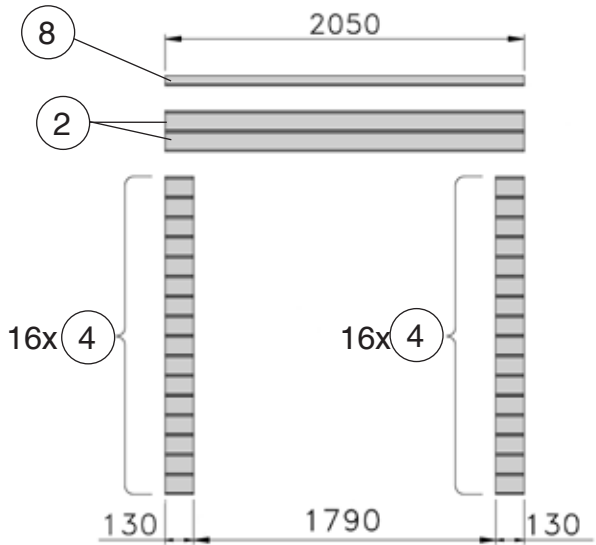

SW

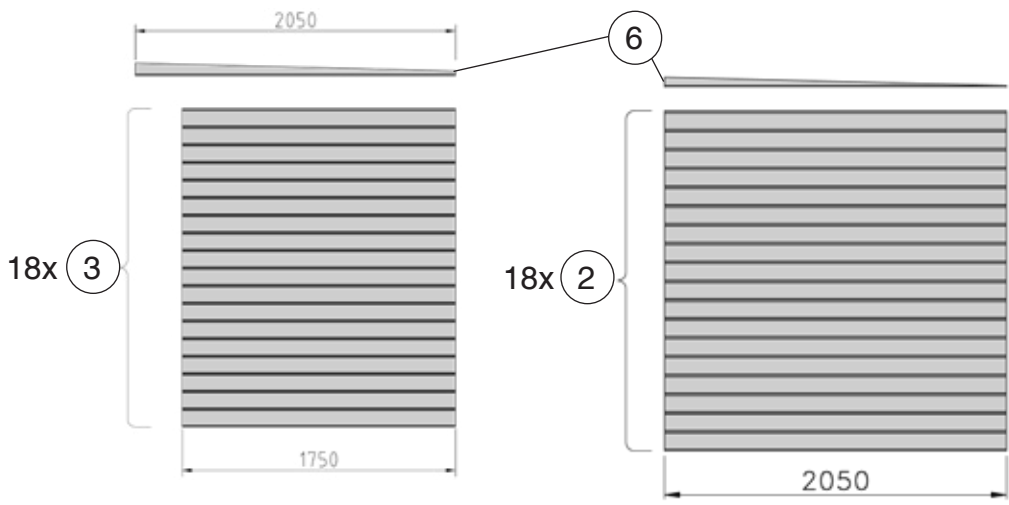

RW

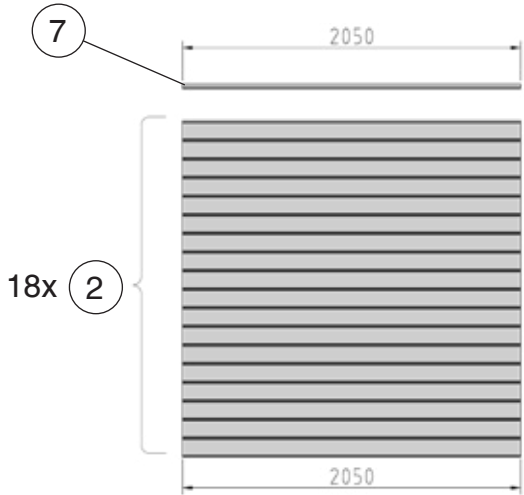

Angaben in mm

Pos	Abmessung	Stück
②	21/121/2050	38
③	21/121/1750	18
④	21/121/130	32
⑥	21/81/2050	2
⑦	21/30/2050	1
⑧	21/73/2050	1

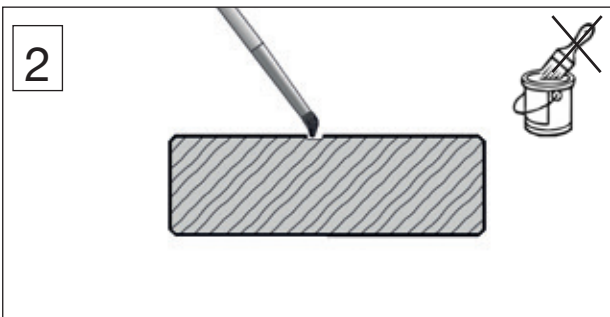
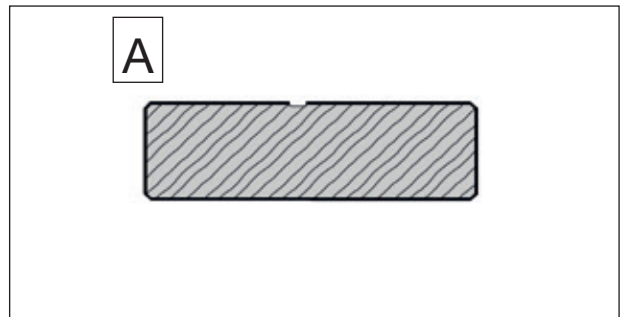
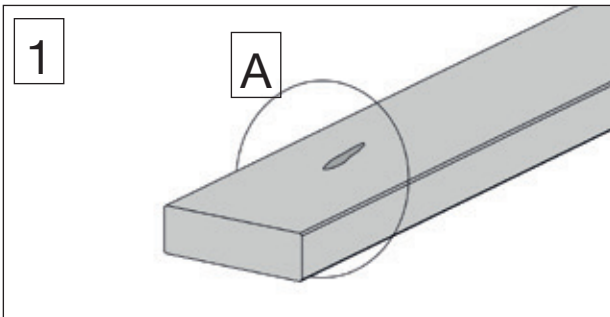
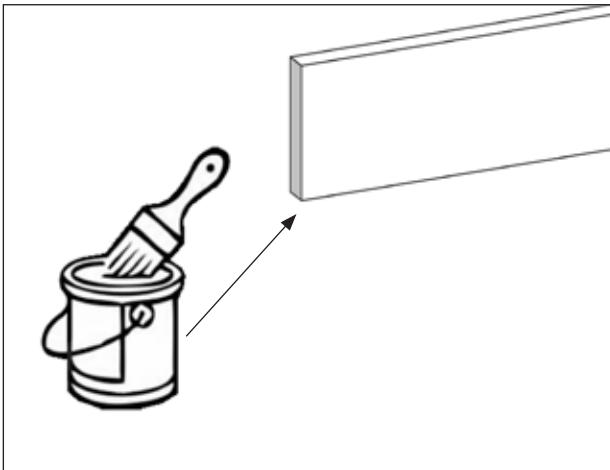
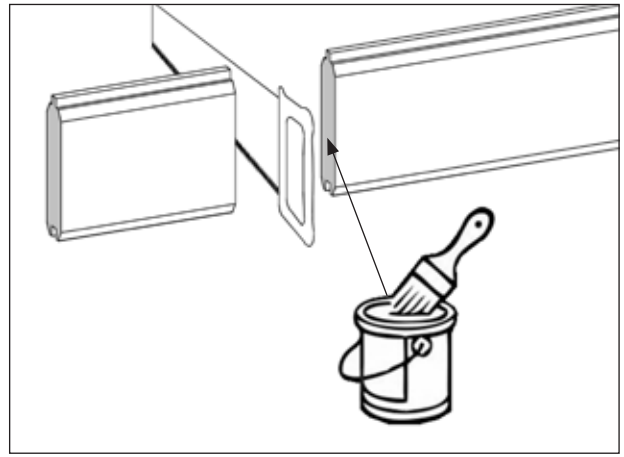
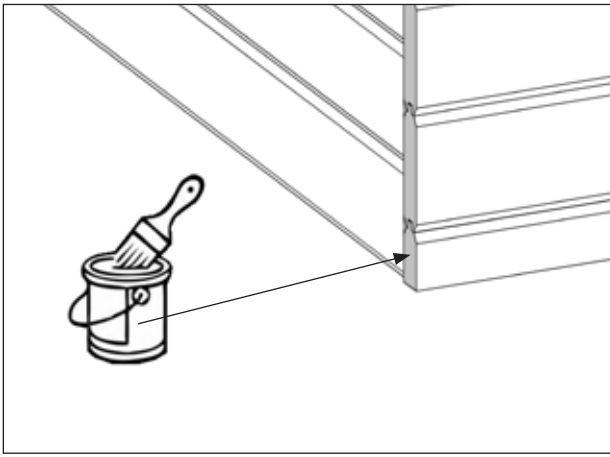

Farbe dünn auftragen und nur auf der Schadstelle.

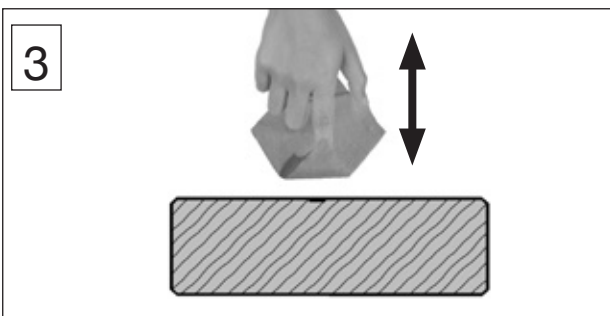
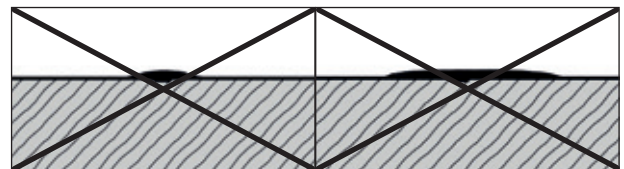

Farbe tupfen
Vorgang wiederholen

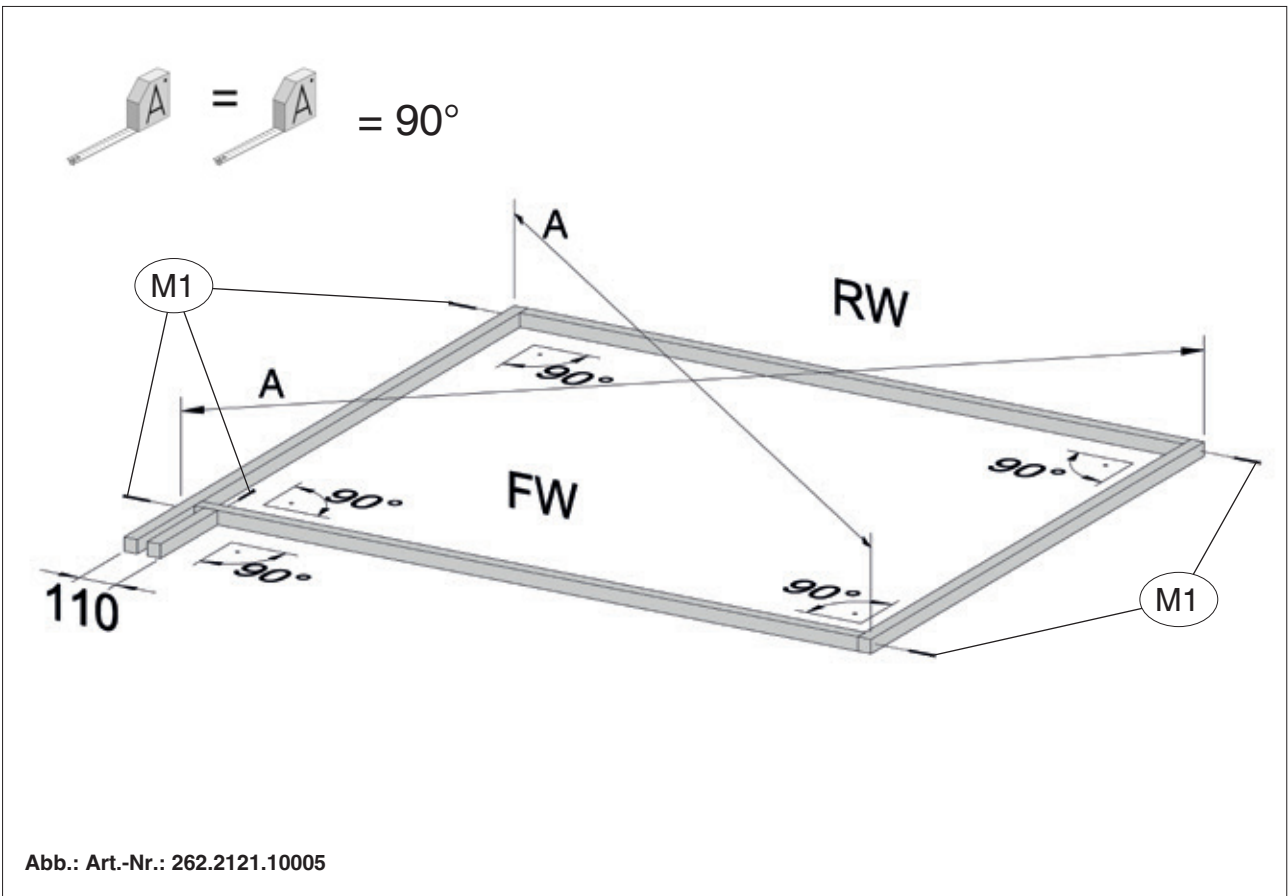
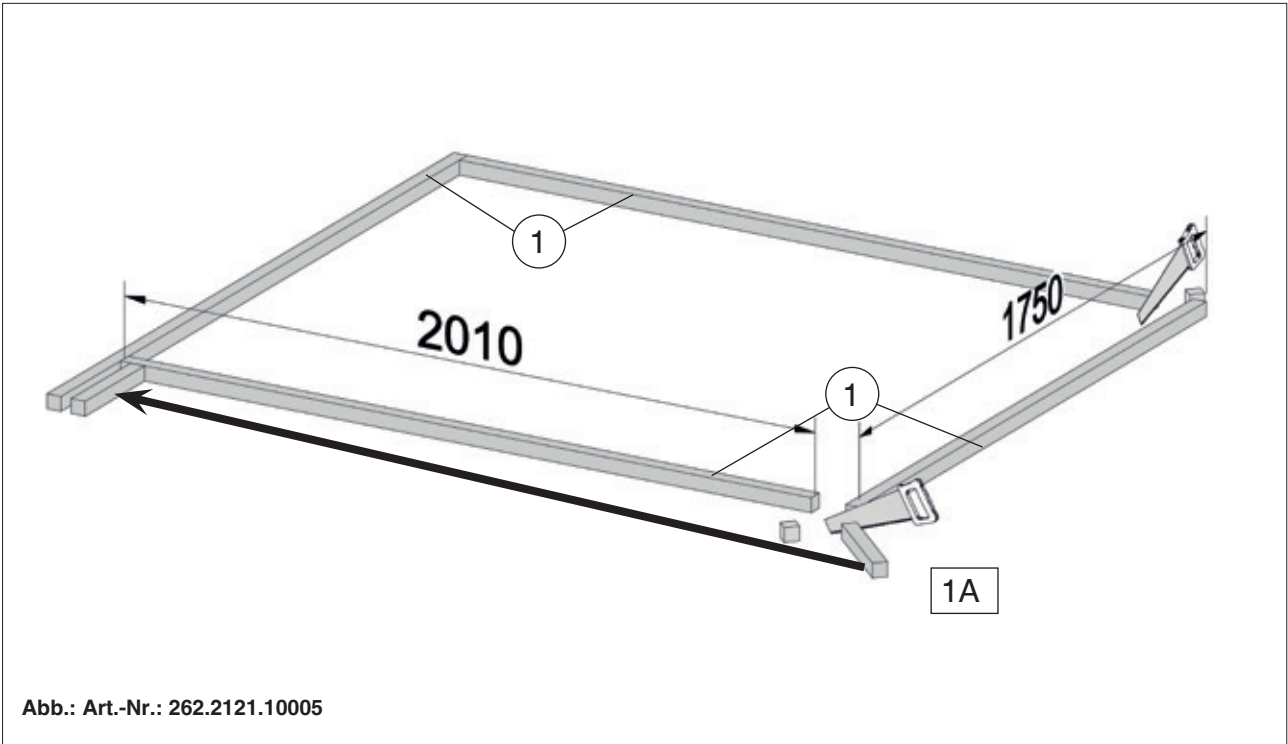
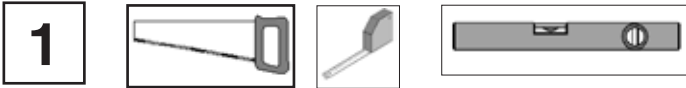

3

	M2	4,0 x 60
	M3	4,0 x 40

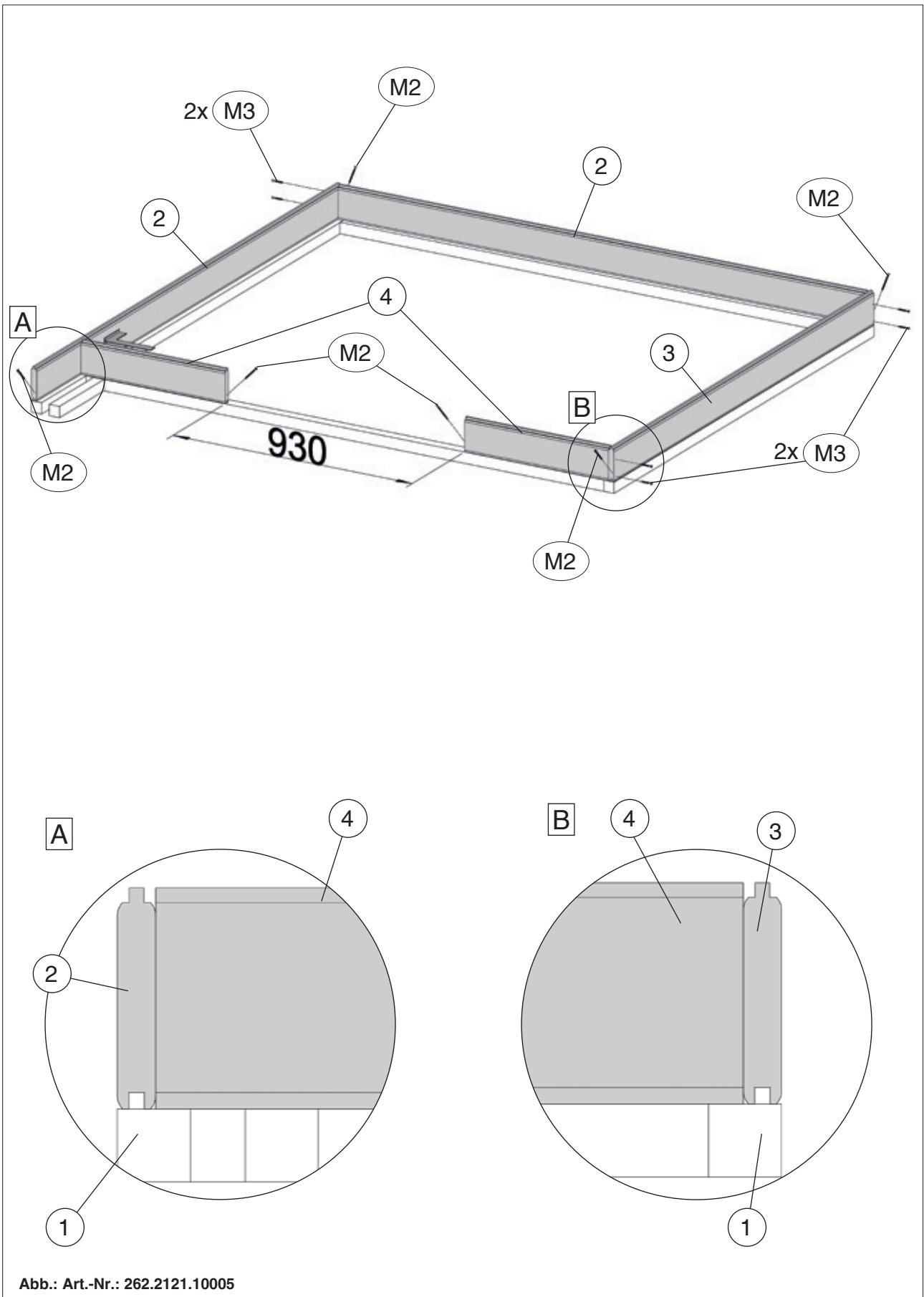

3

	M2	4,0 x 60
	M3	4,0 x 40

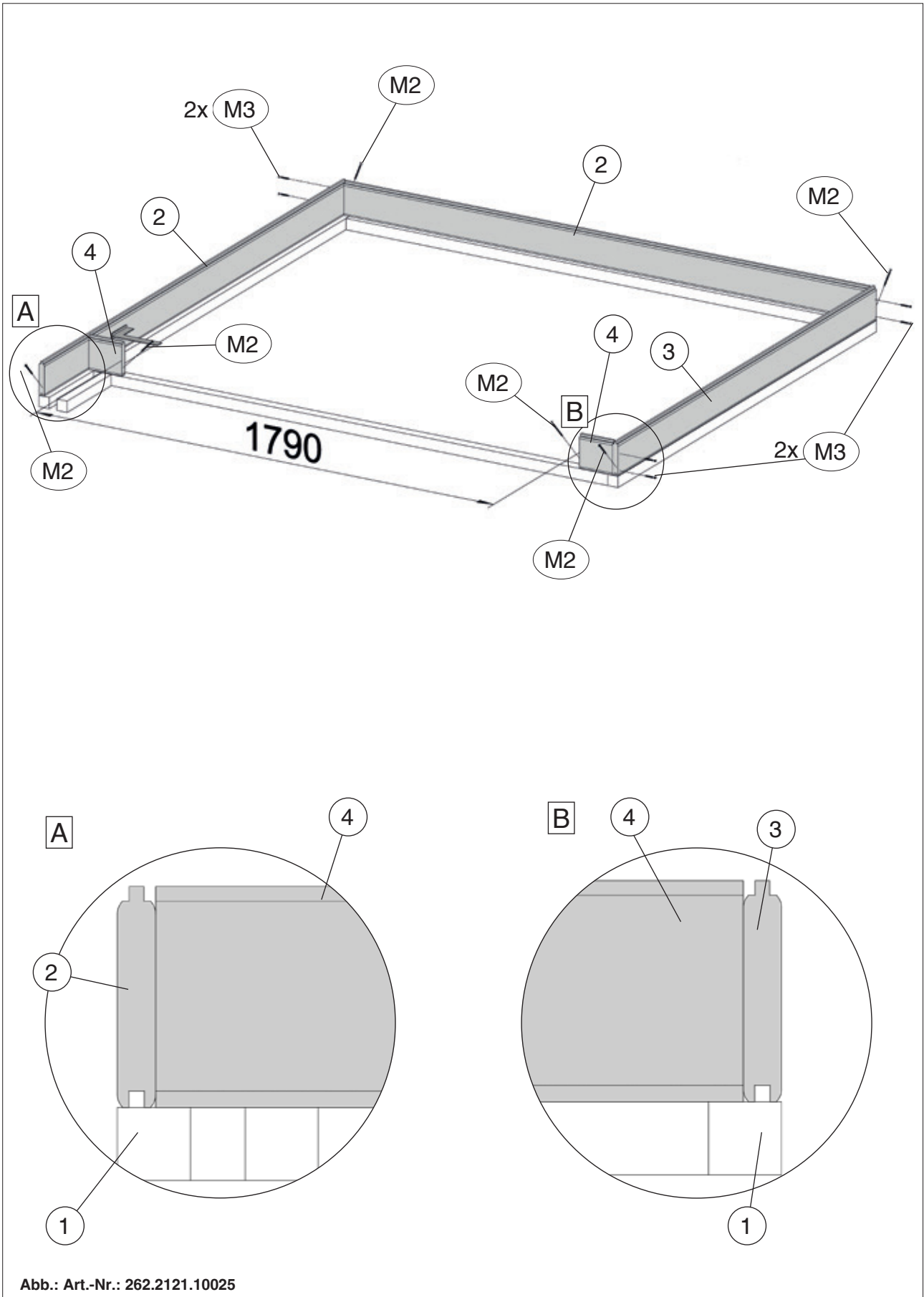

4

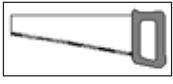

! 262.2121.1x000
262.2121.1x010
262.2121.1x020
262.2121.1x030



Abb.: Art.-Nr.: 262.2121.10000

5



M6 2,2 x 55

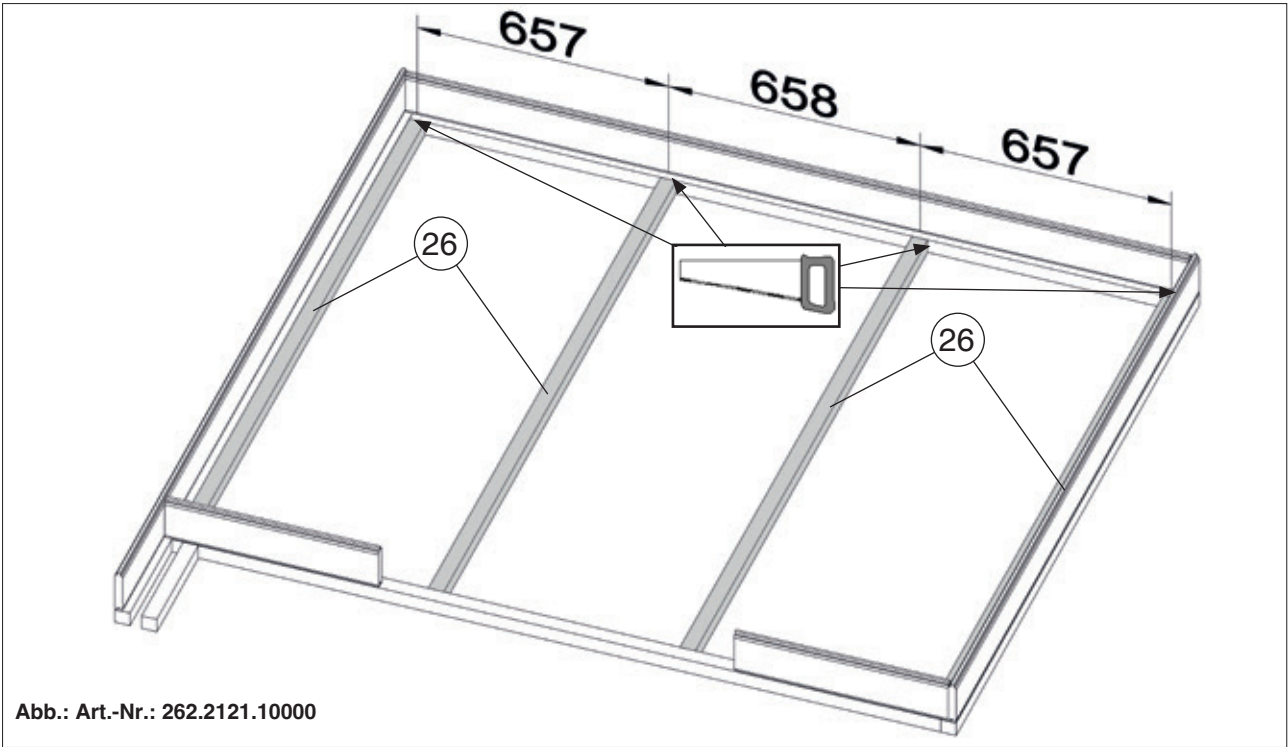
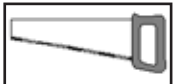

Abb.: Art.-Nr.: 262.2121.10000

6

	M5 5,0 x 20
	M7

	M3 4,0 x 40

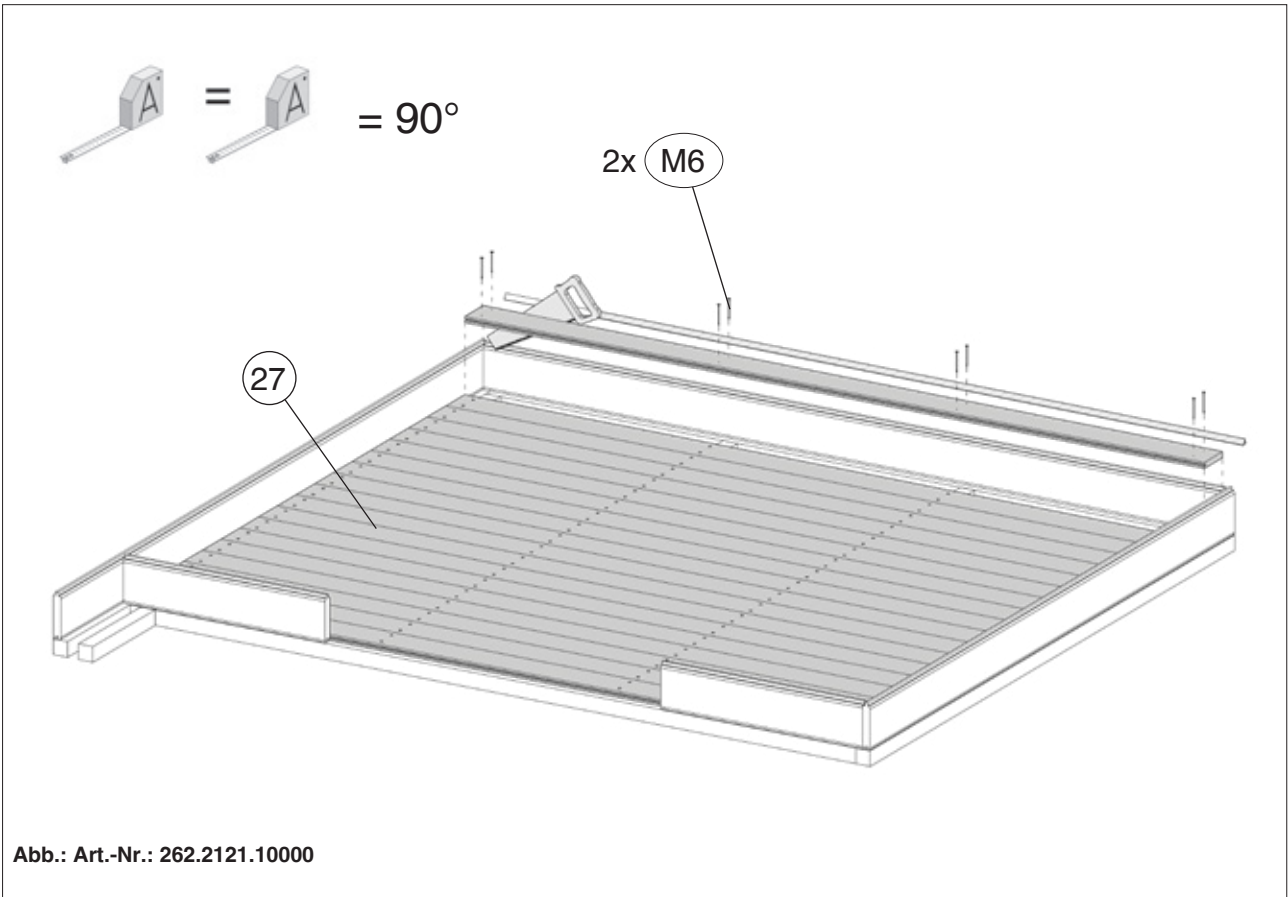
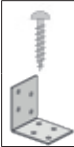
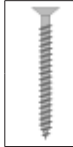



Abb.: Art.-Nr.: 262.2121.10005

7

	M2	4,0 x 60
	M5	5,0 x 20

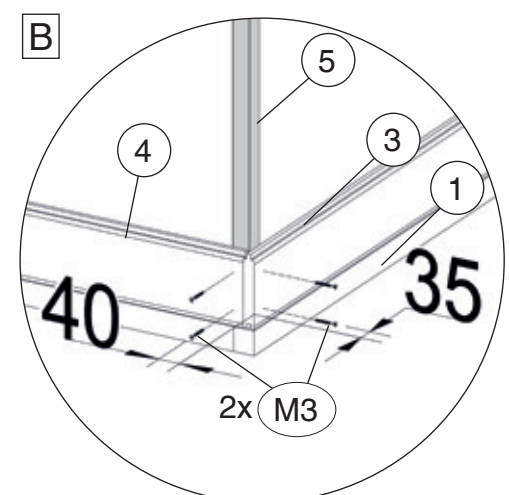
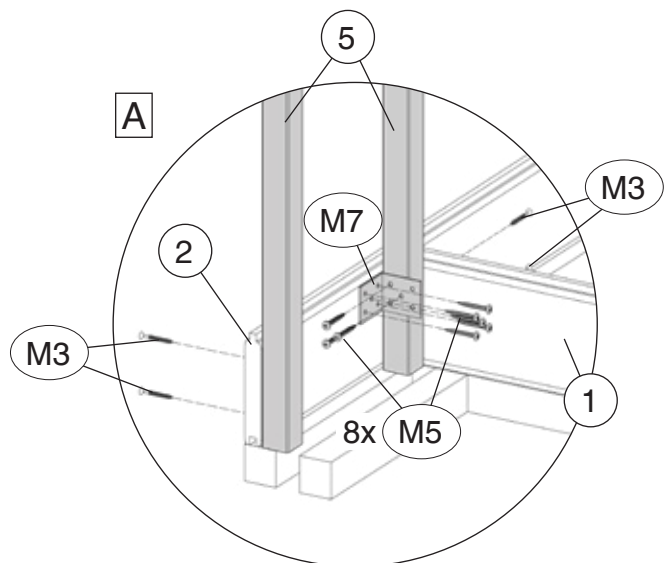
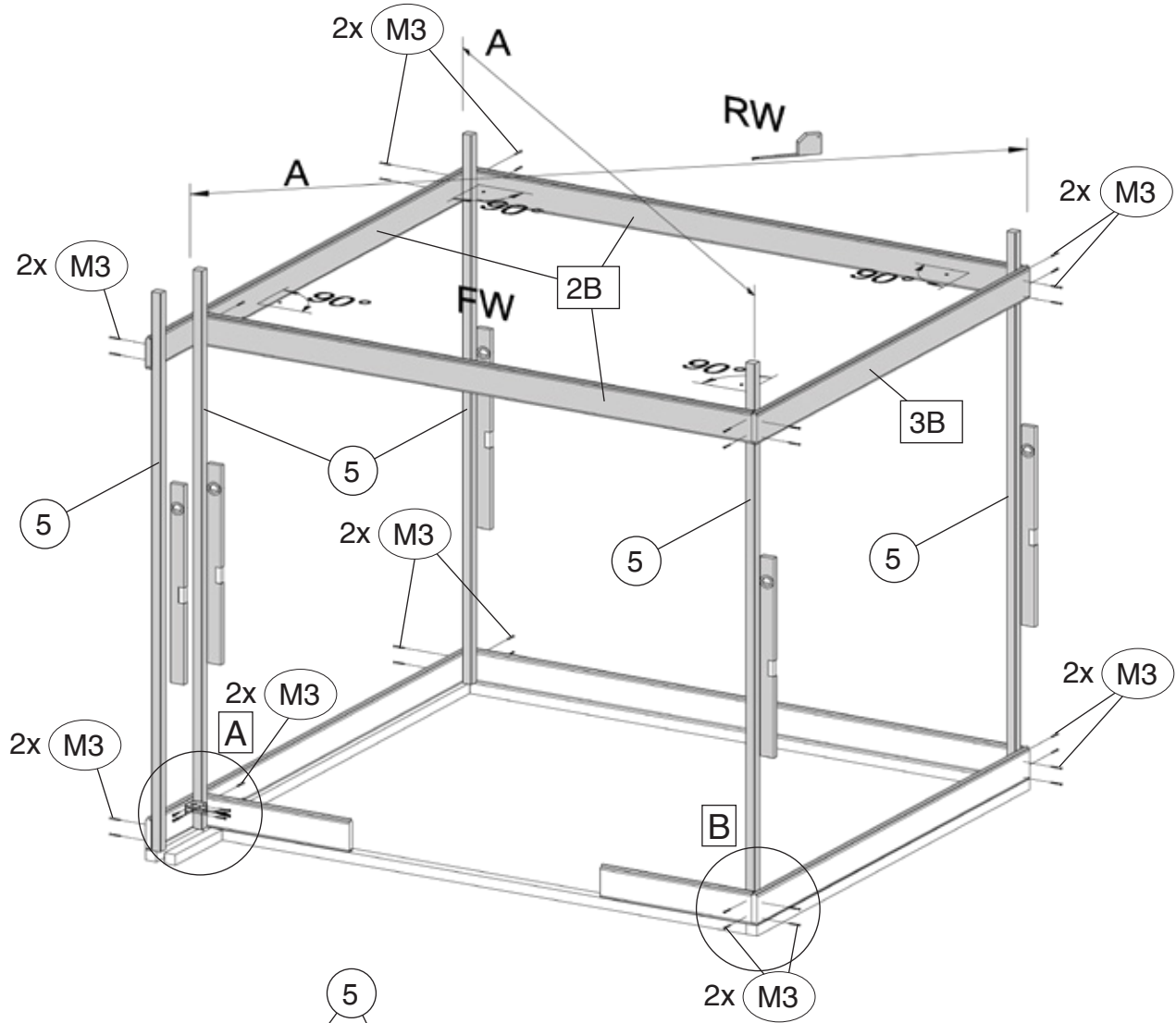

Abb.: Art.-Nr.: 262.2121.10005

8

	M5 5,0 x 20
	M7

	M3 4,0 x 40

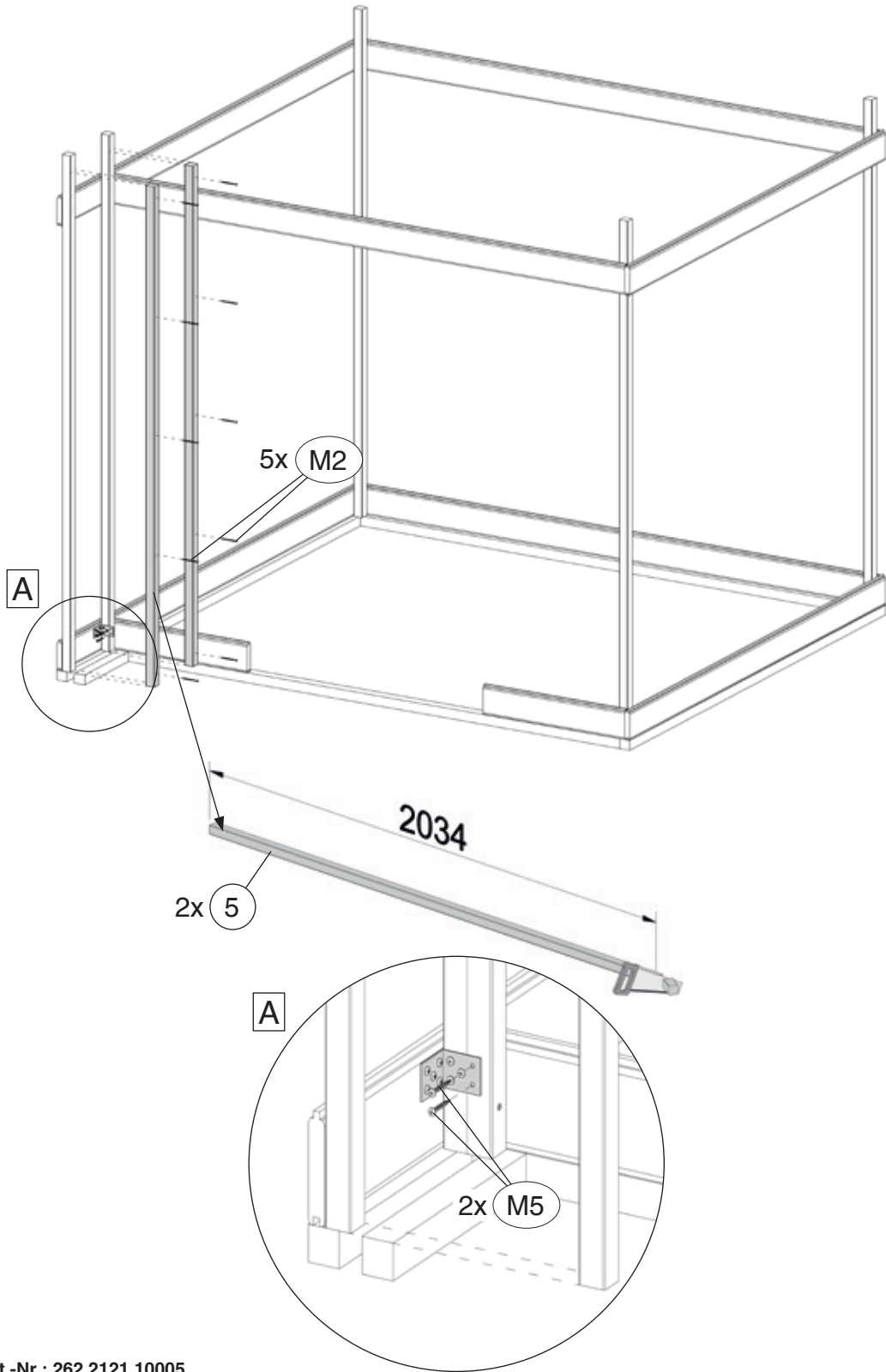
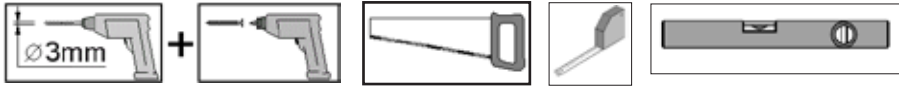
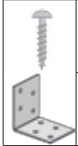



Abb.: Art.-Nr.: 262.2121.10005

8

	M5 5,0 x 20
	M7

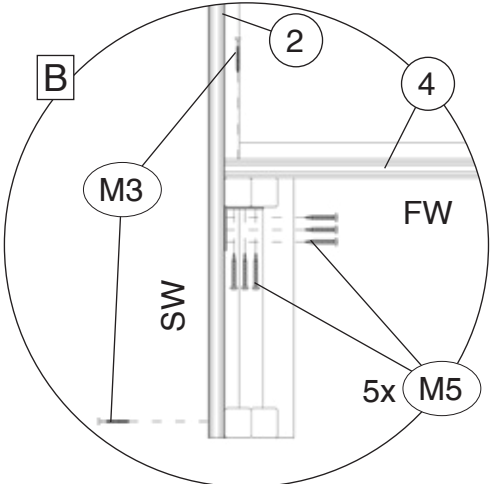
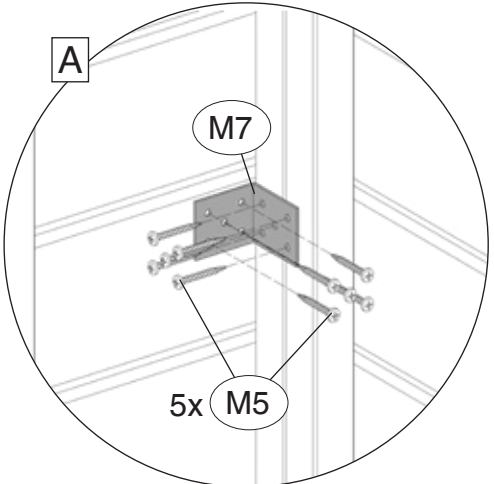
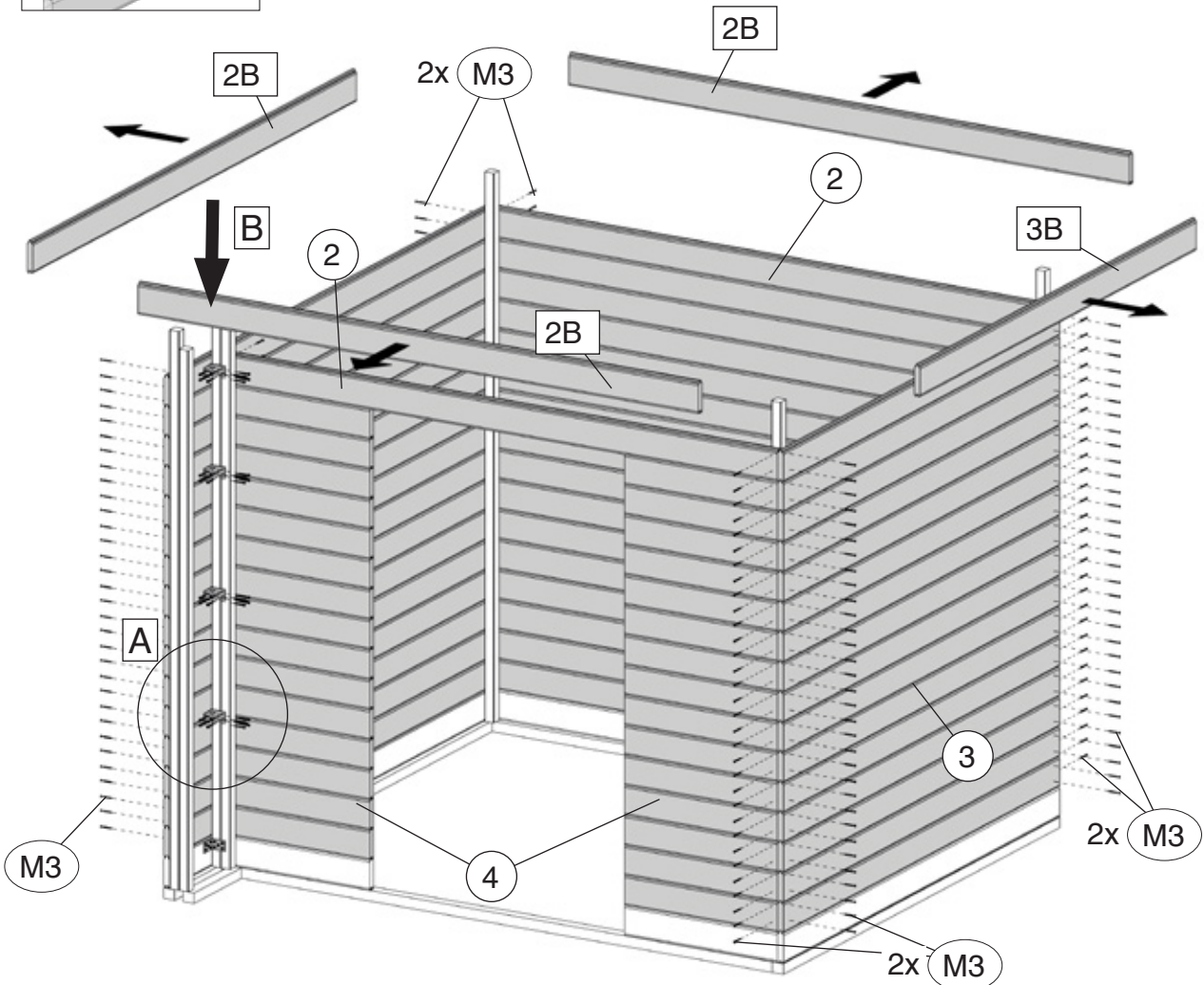
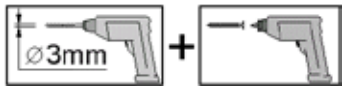
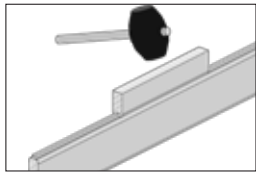
	M3 4,0 x 40



Abb.: Art.-Nr.: 262.2121.10025

9



10

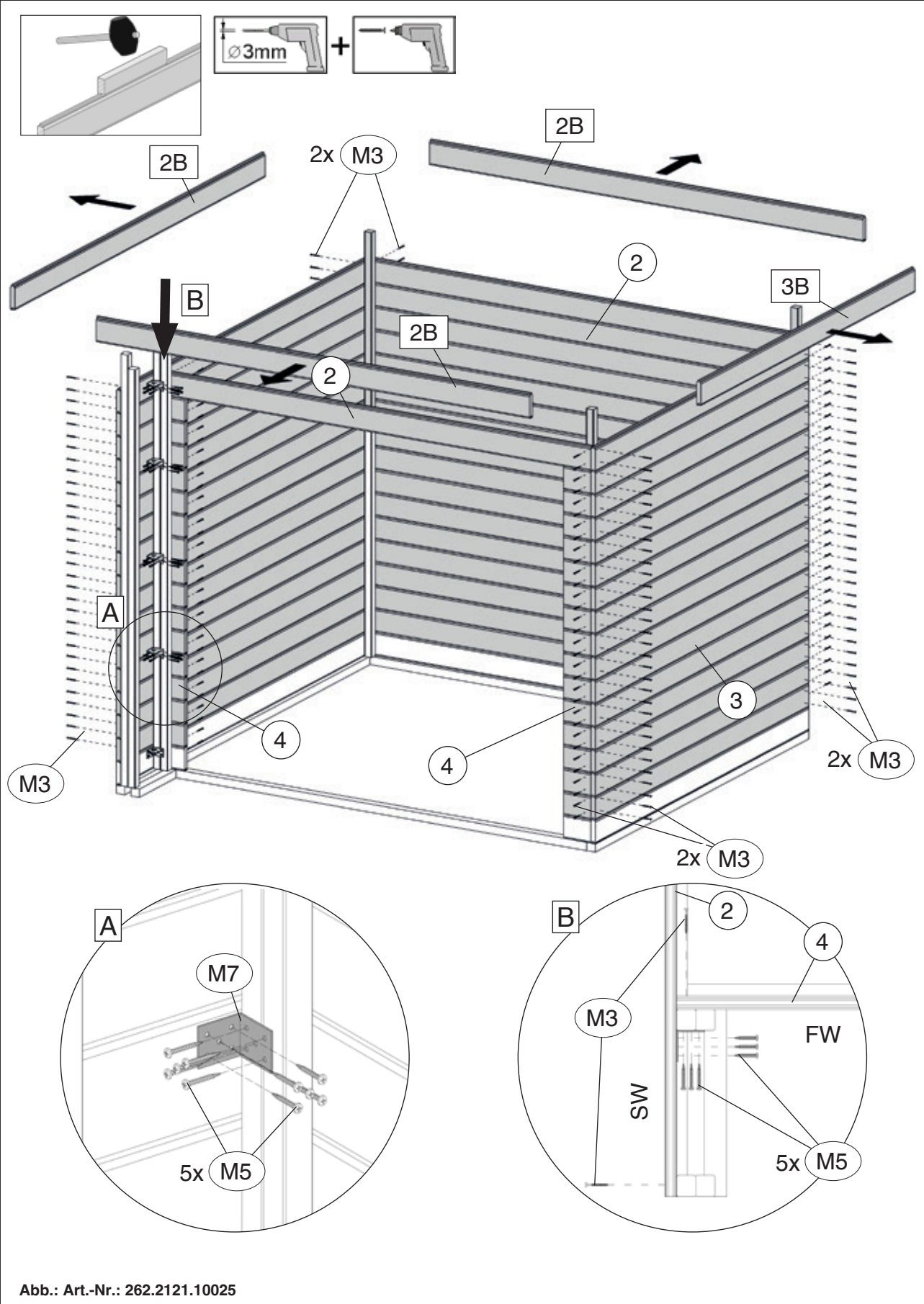
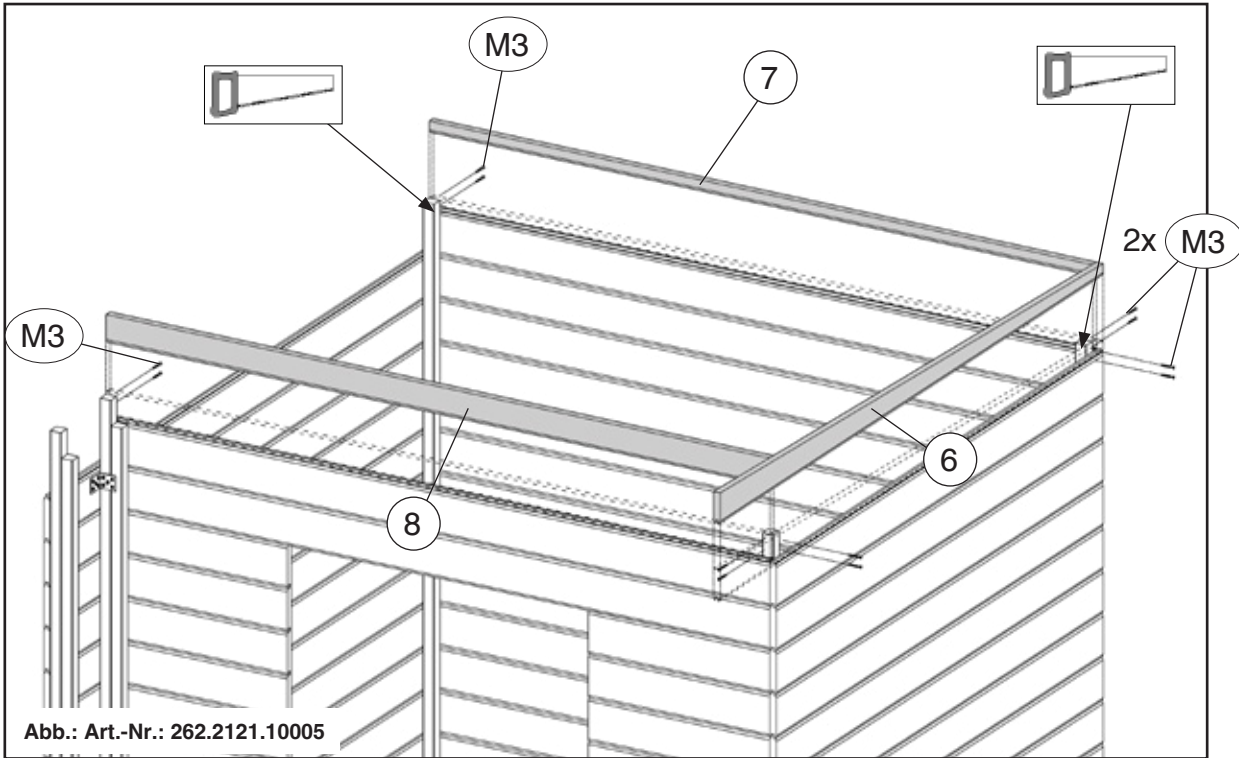
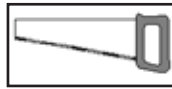
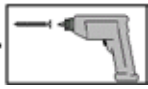
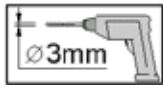
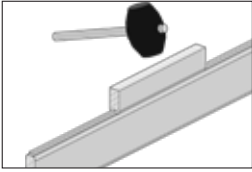
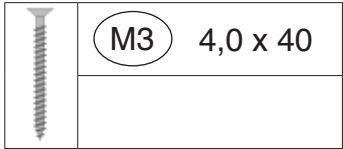
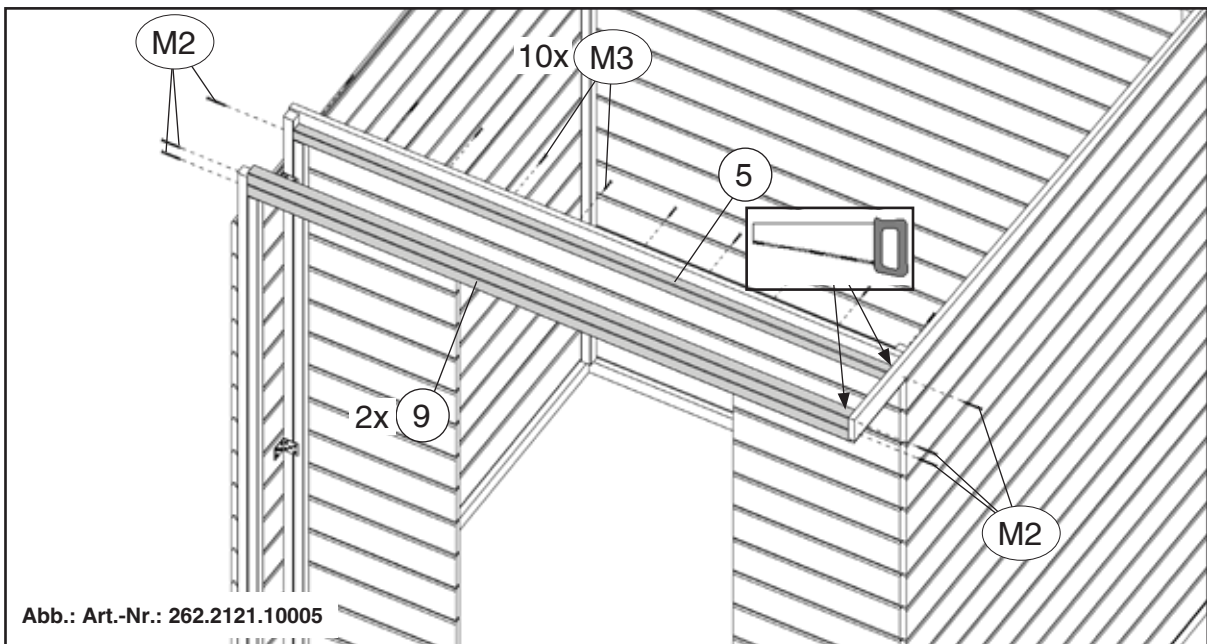

11

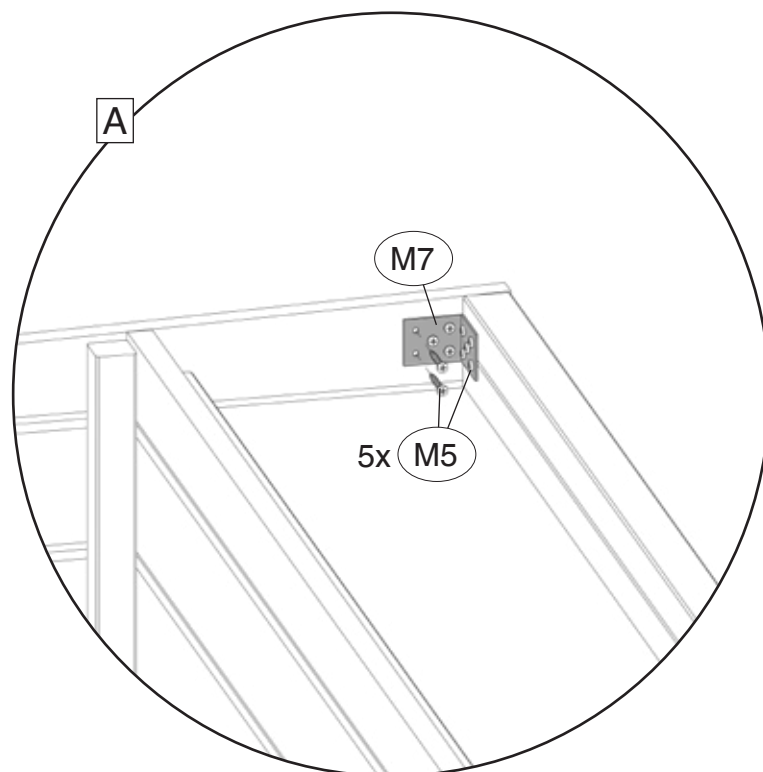
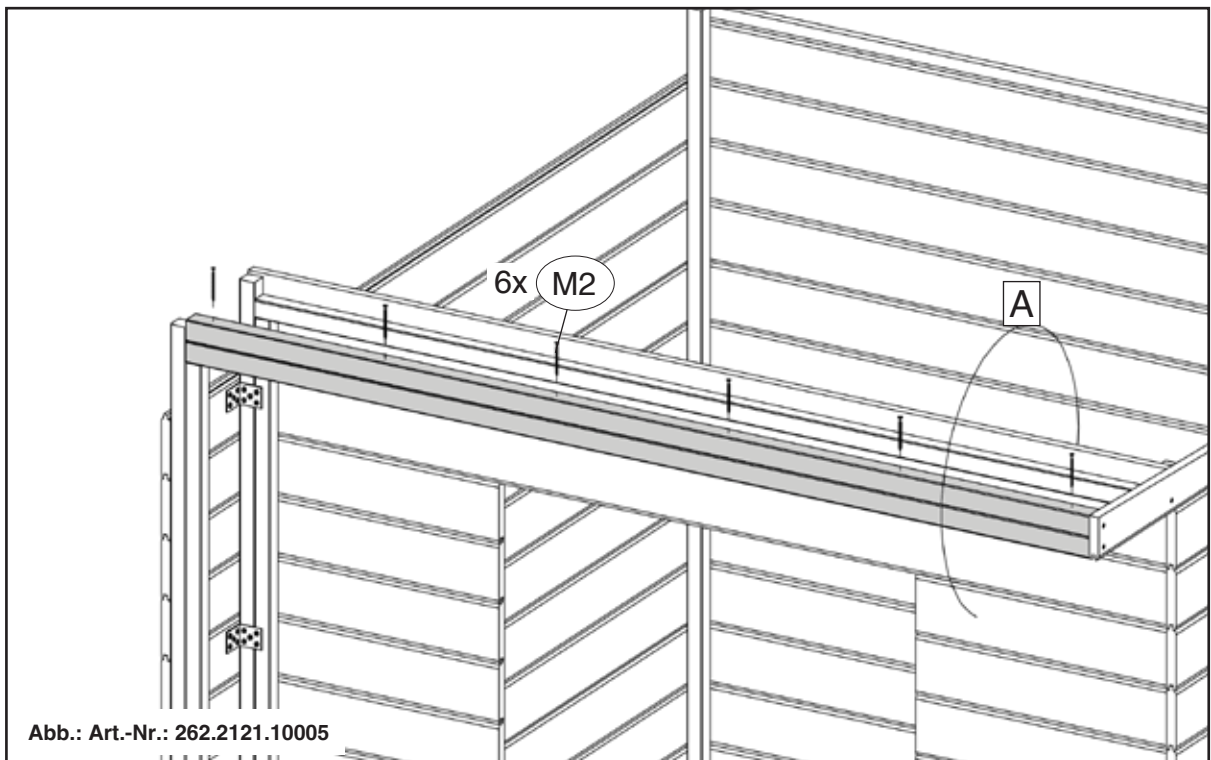
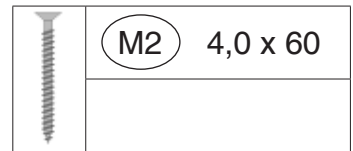
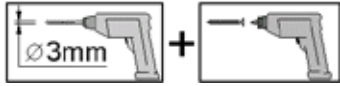

12

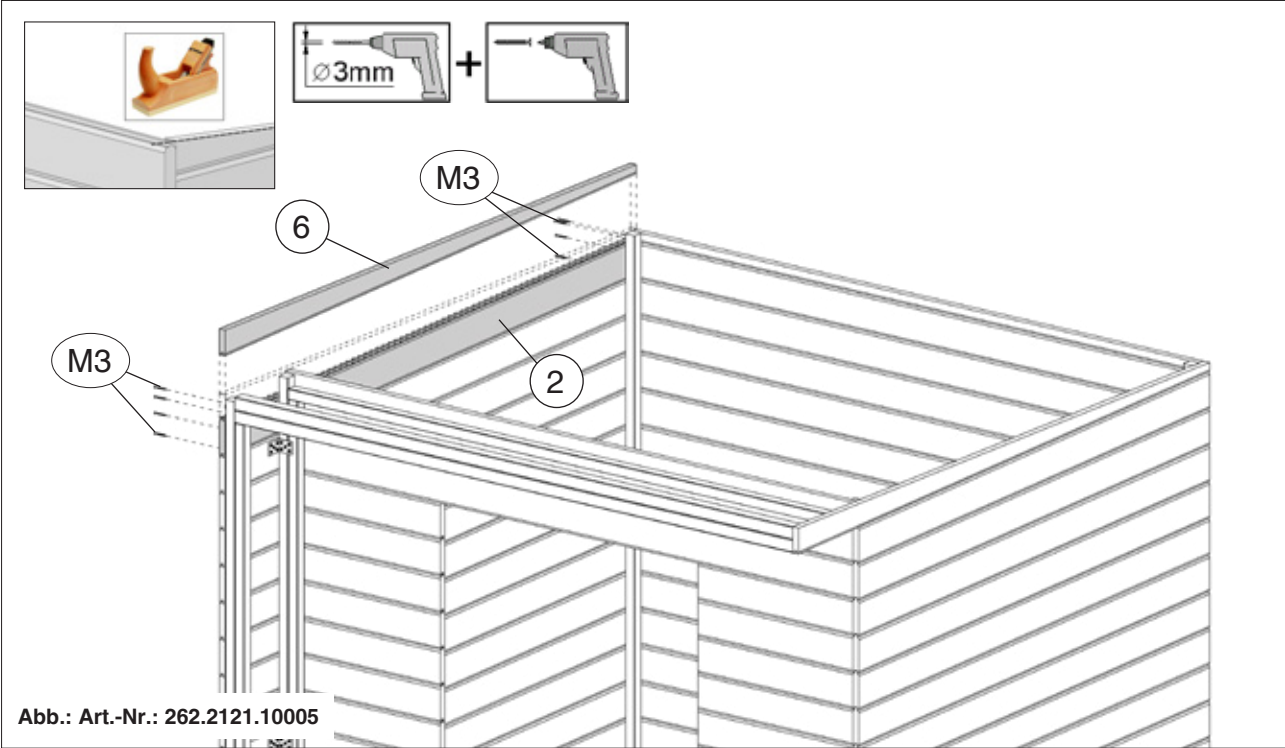
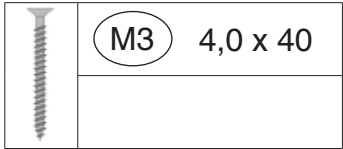

13

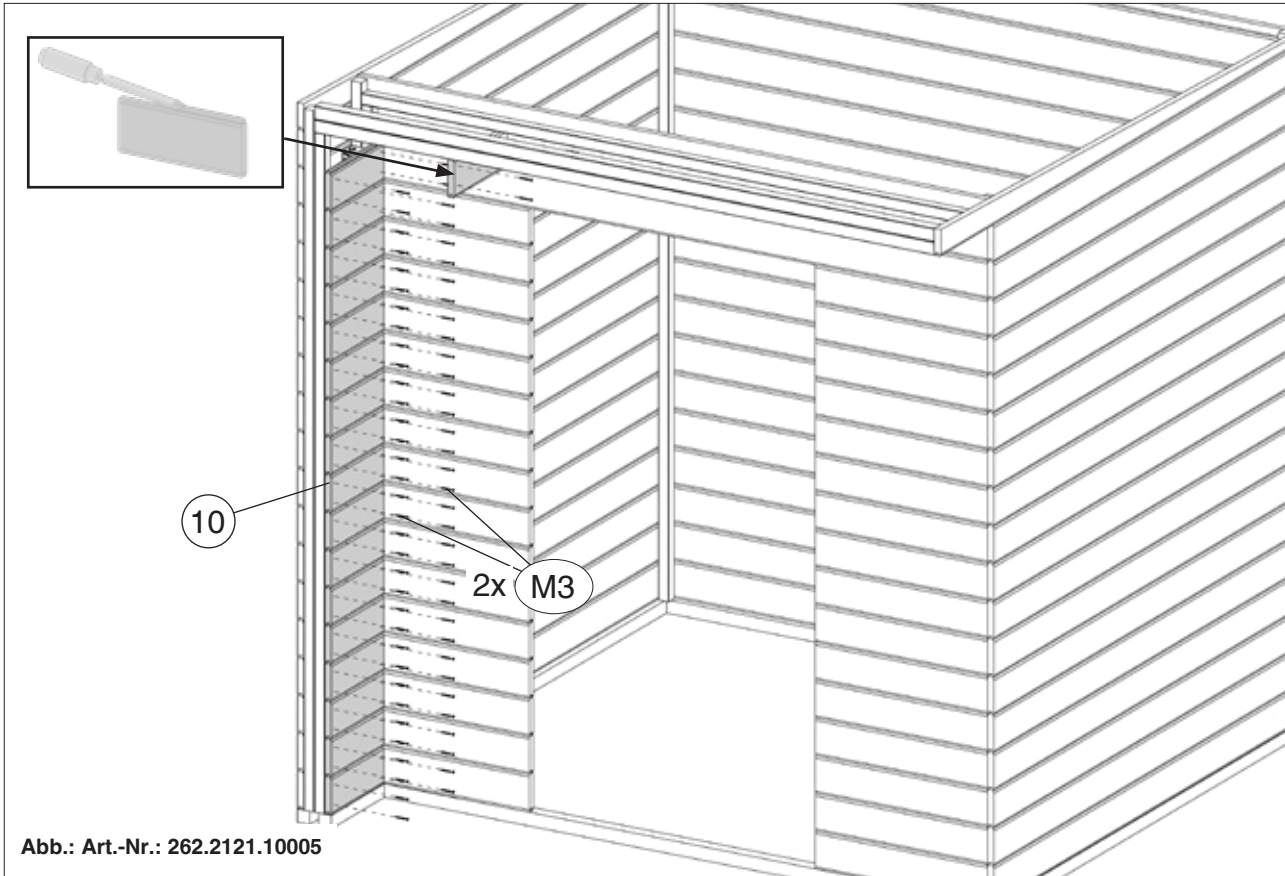
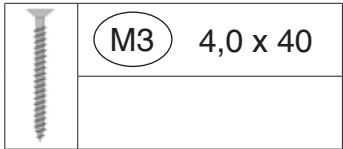
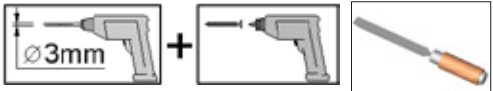

14

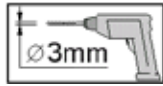

+

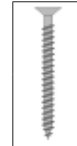
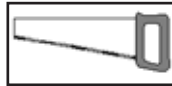
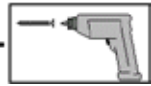

M3 4,0 x 40

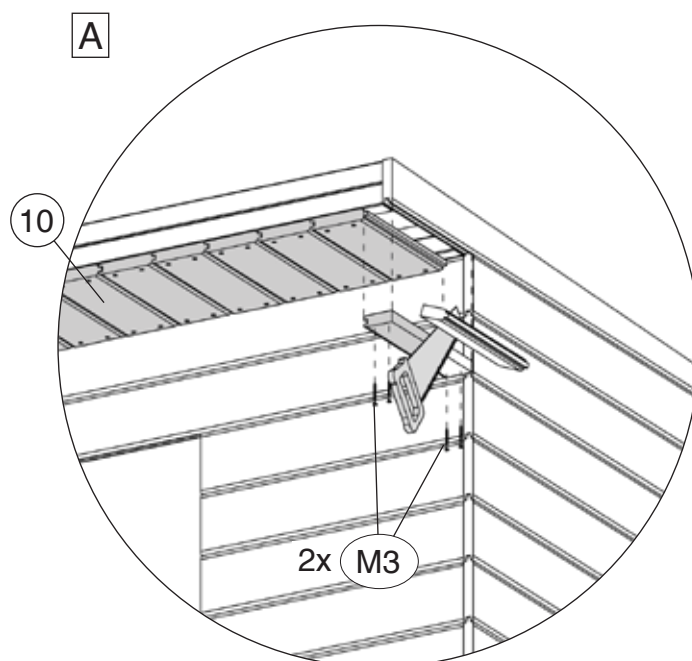
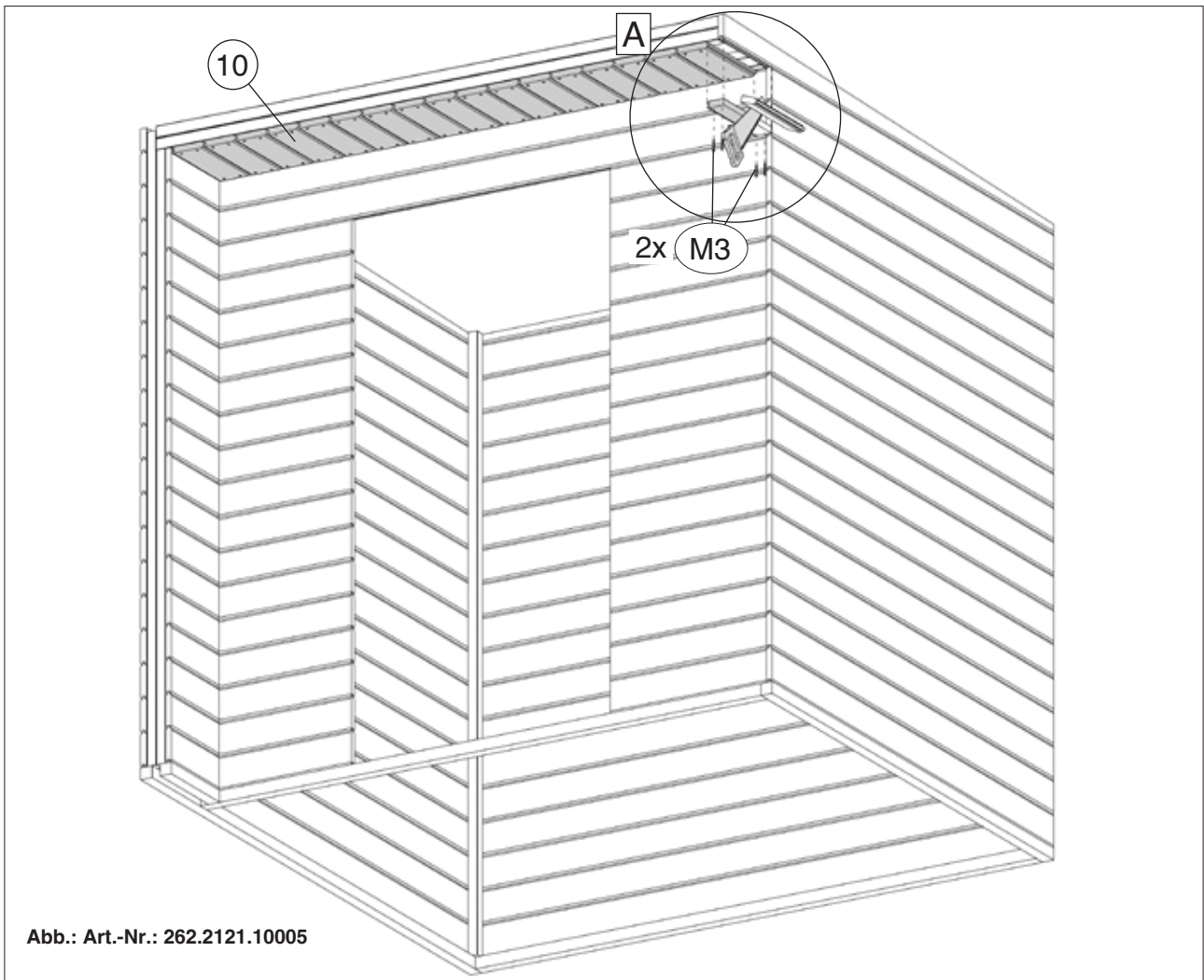

15

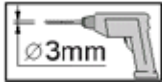

M5 5,0 x 20



Abb.: Art.-Nr.: 262.2121.10005

a = a



15.1

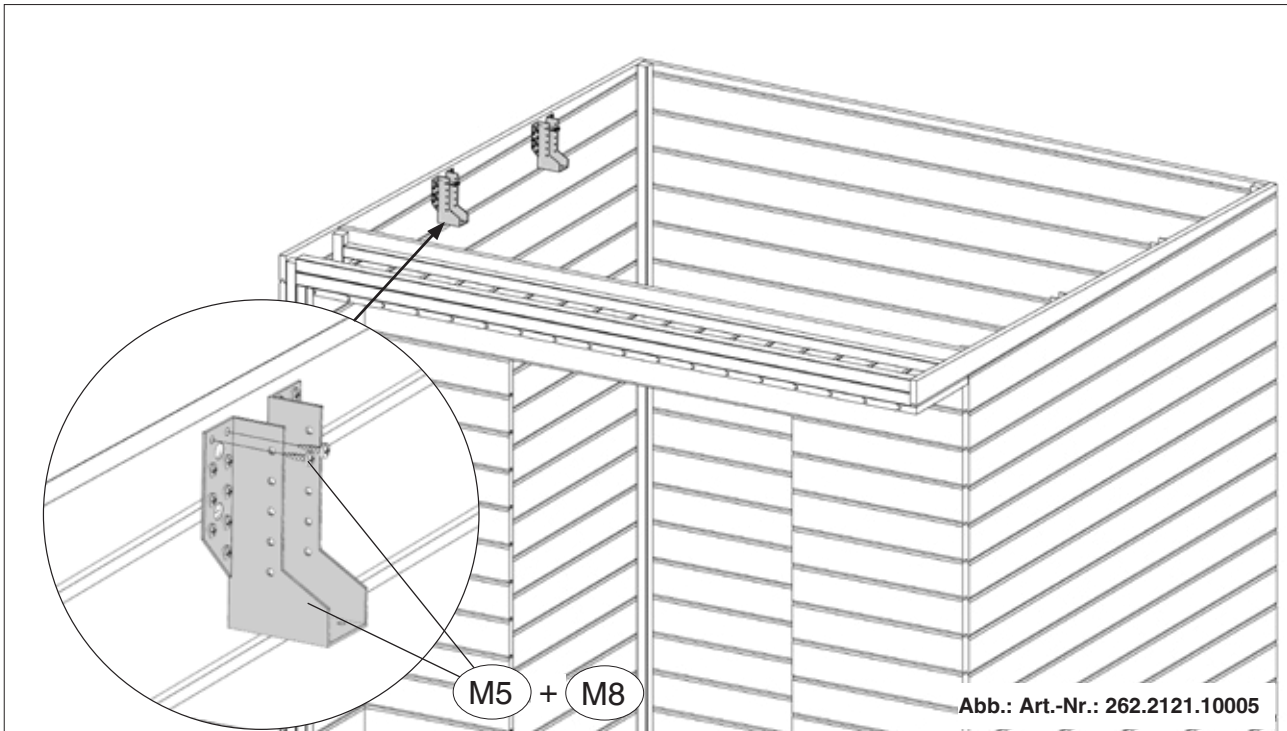
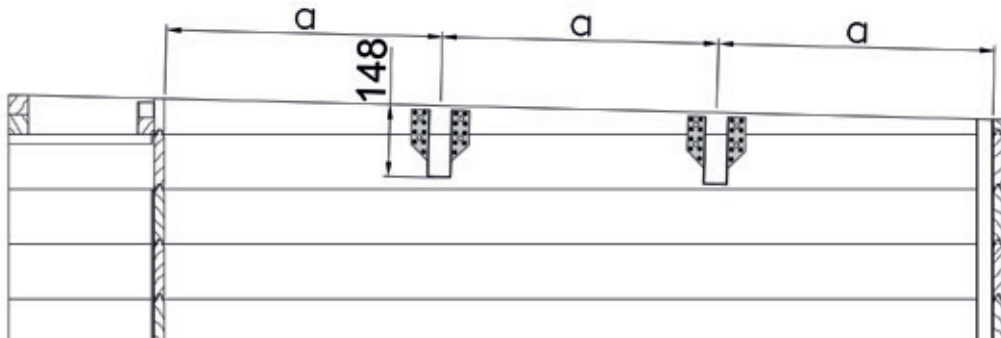

Abb.: Art.-Nr.: 262.2121.10005

16



M6 2,2 x 55

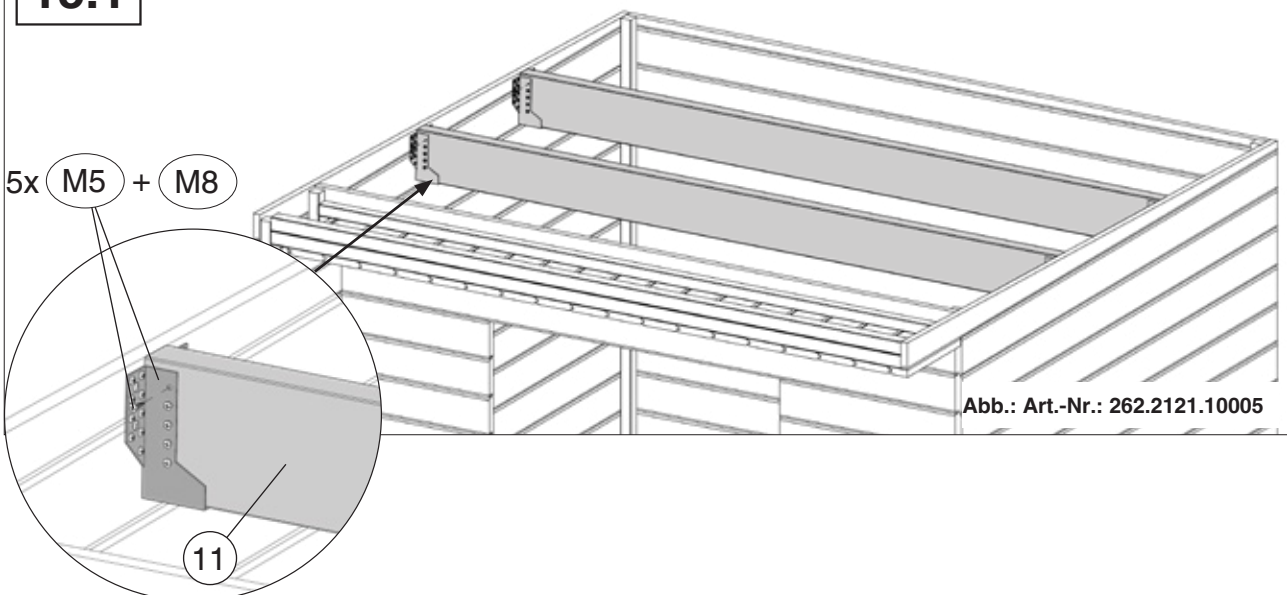
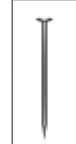
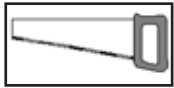
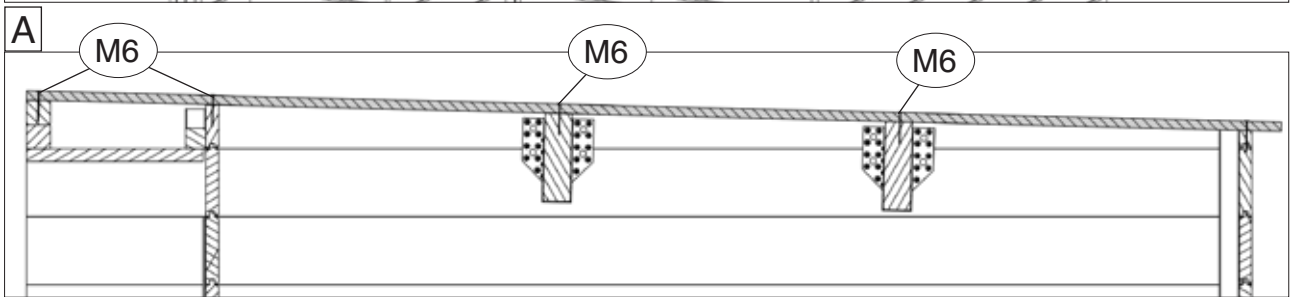
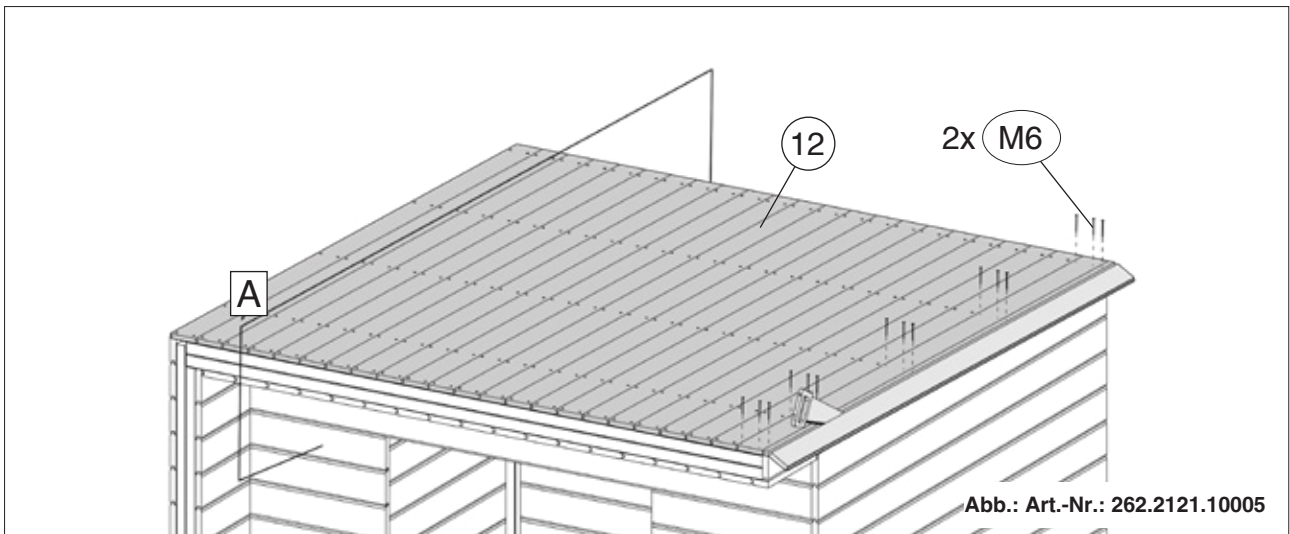

17

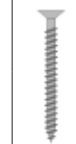
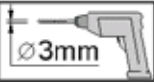

M4 3,5 x 30

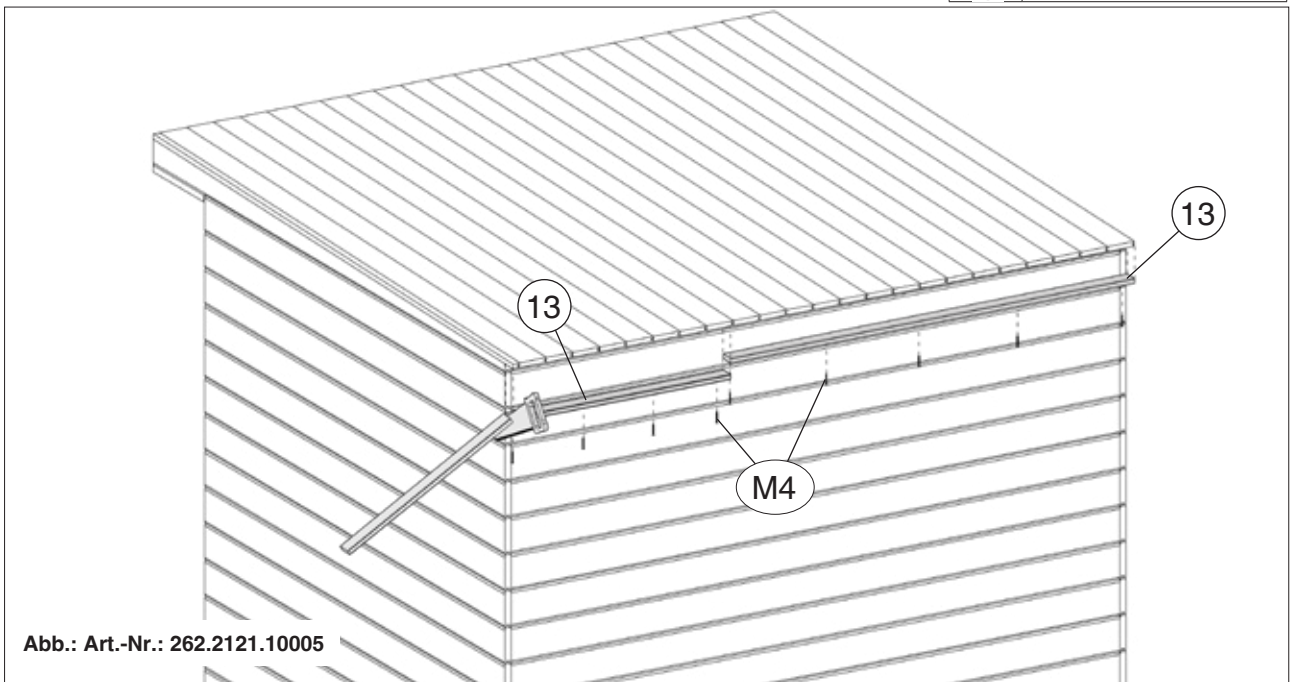

18

- ! 262.2121.1x000
- 262.2121.1x010
- 262.2121.1x020
- 262.2121.1x030

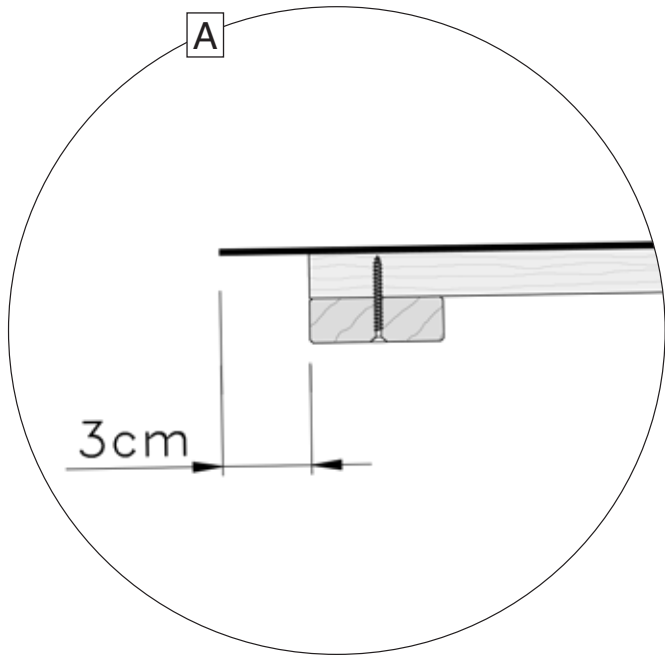
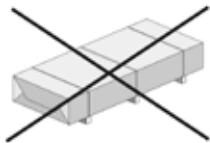
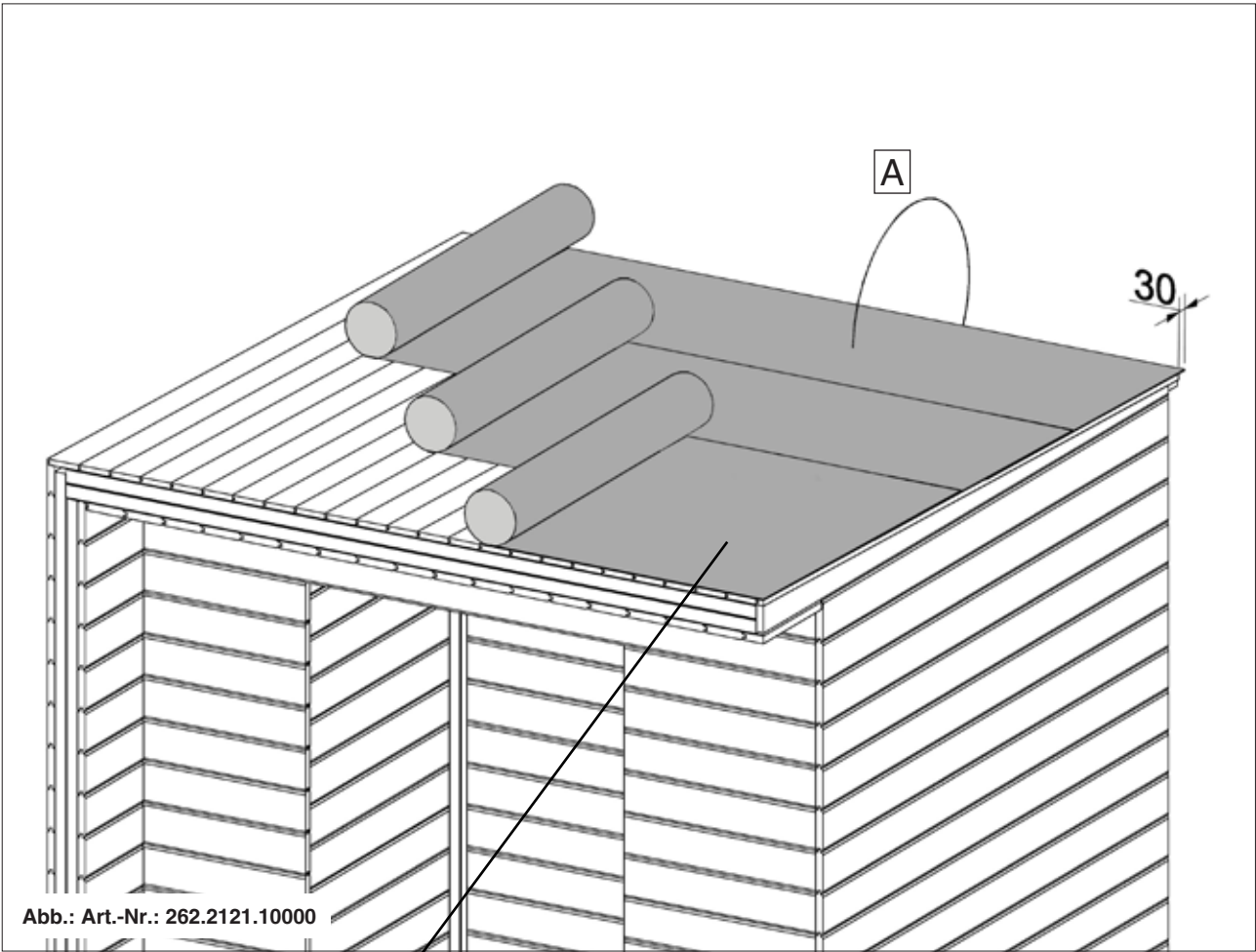

19

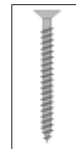
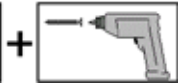
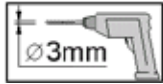

M4 3,5 x 30

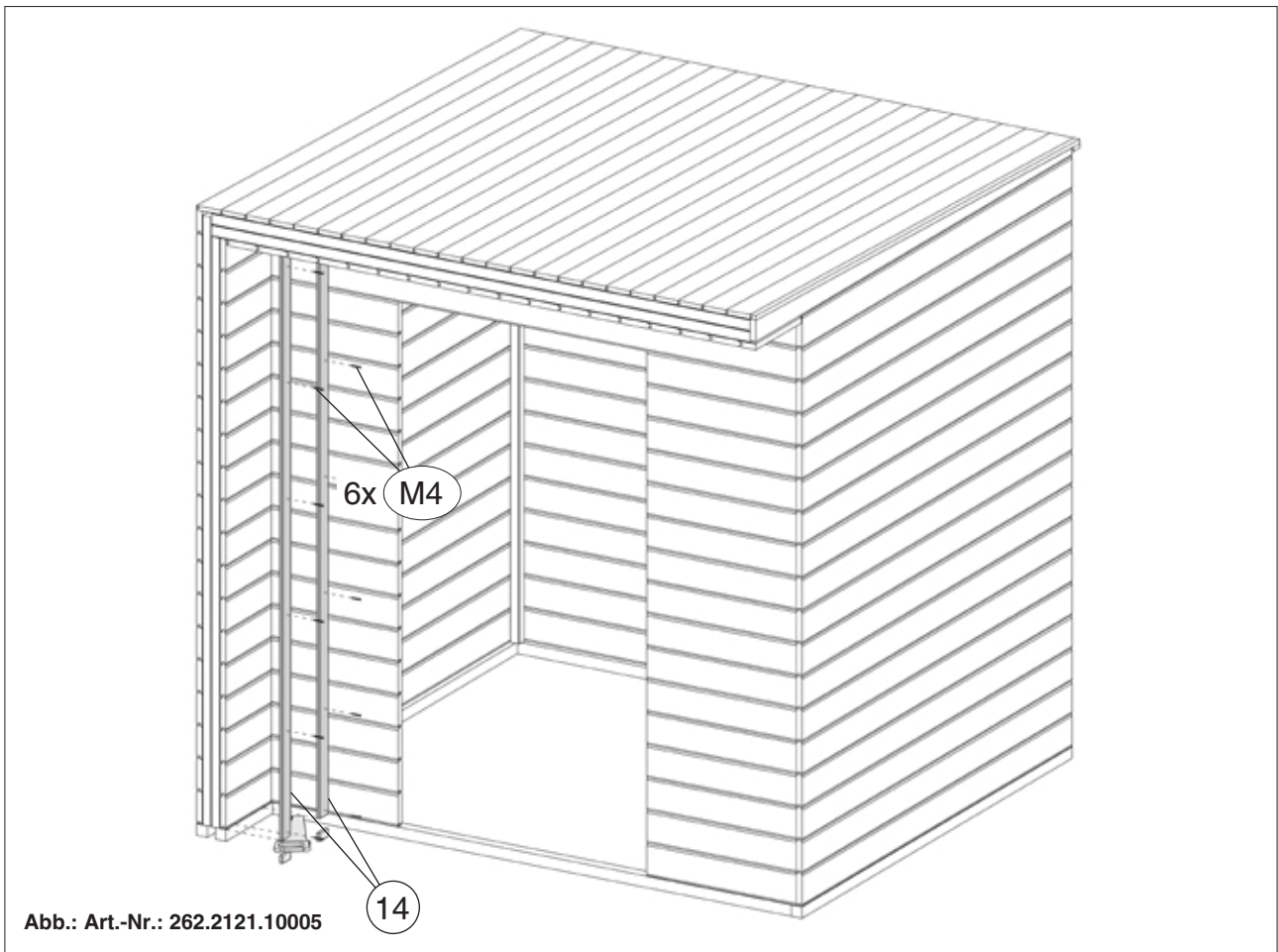

19.1

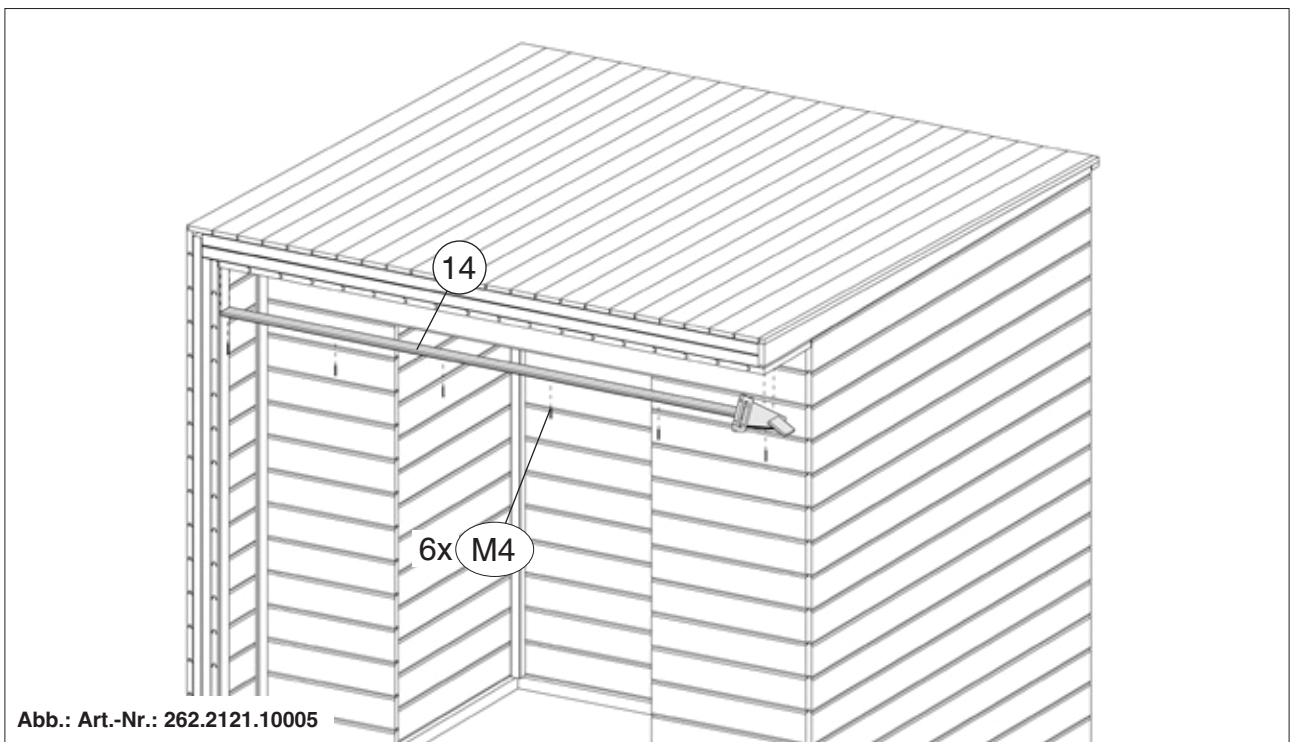
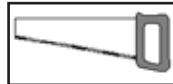
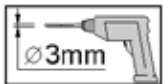

20

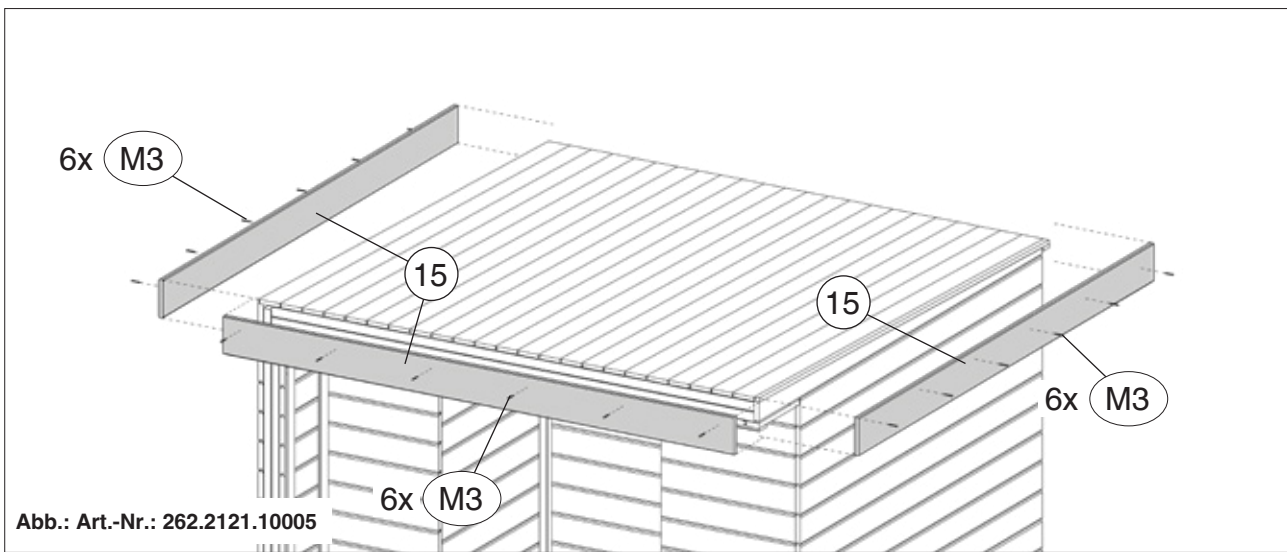
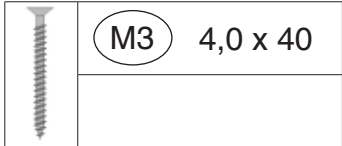
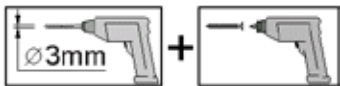

20.1

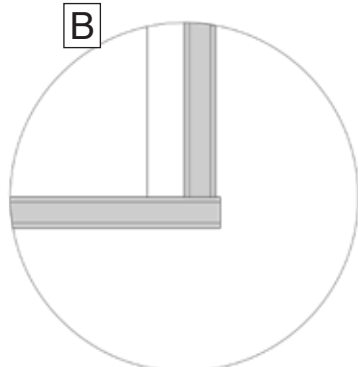
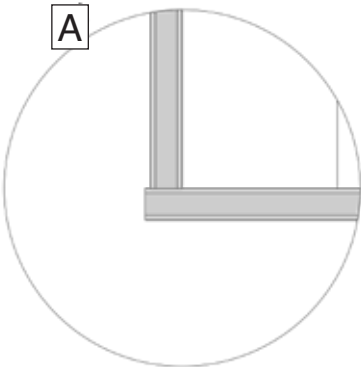
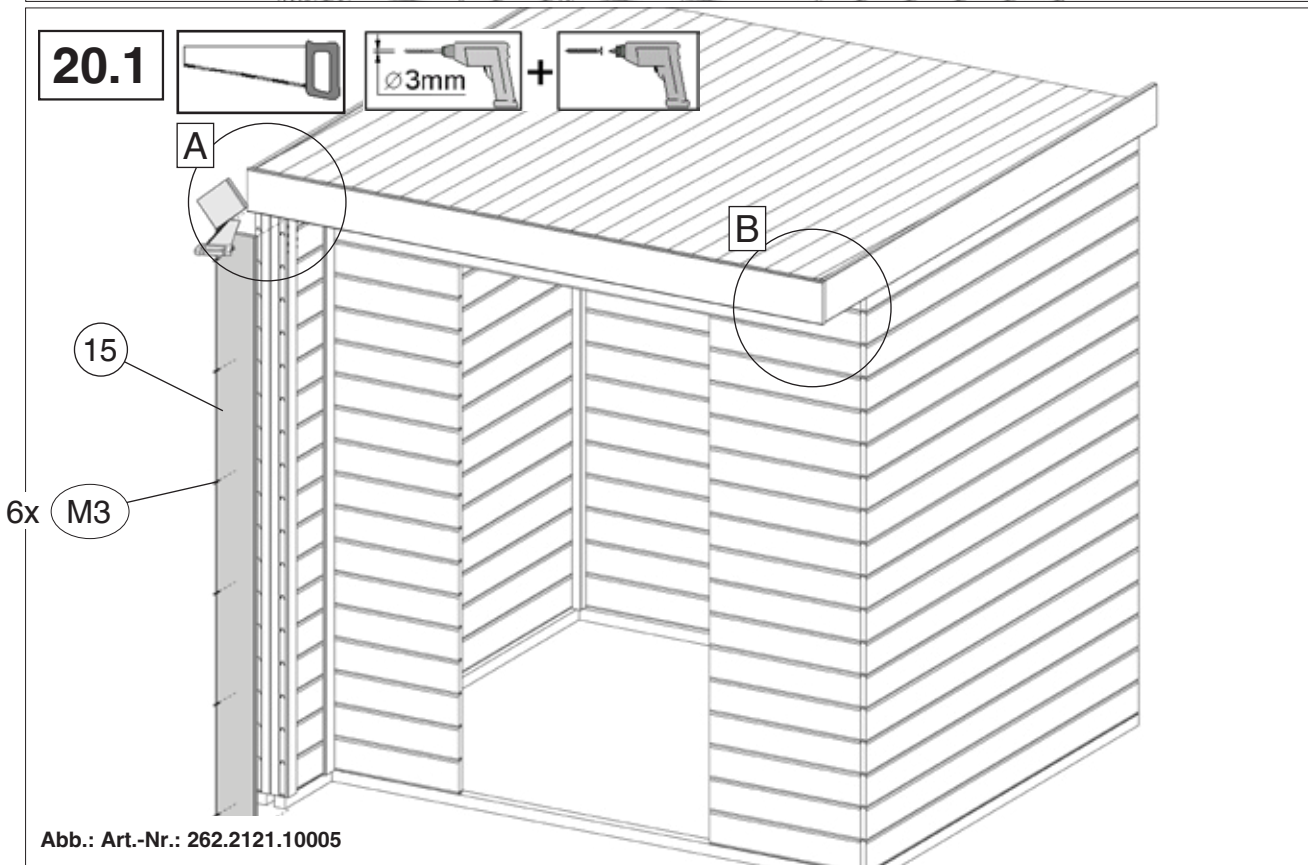
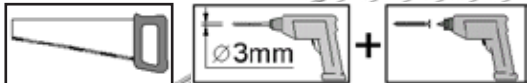

21

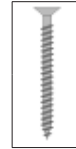
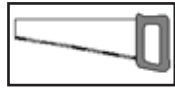
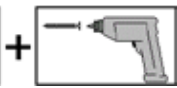
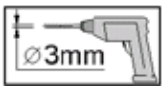

M4 3,5 x 30



Abb.: Art.-Nr.: 262.2121.10005



Abb.: Art.-Nr.: 262.2121.10005

22

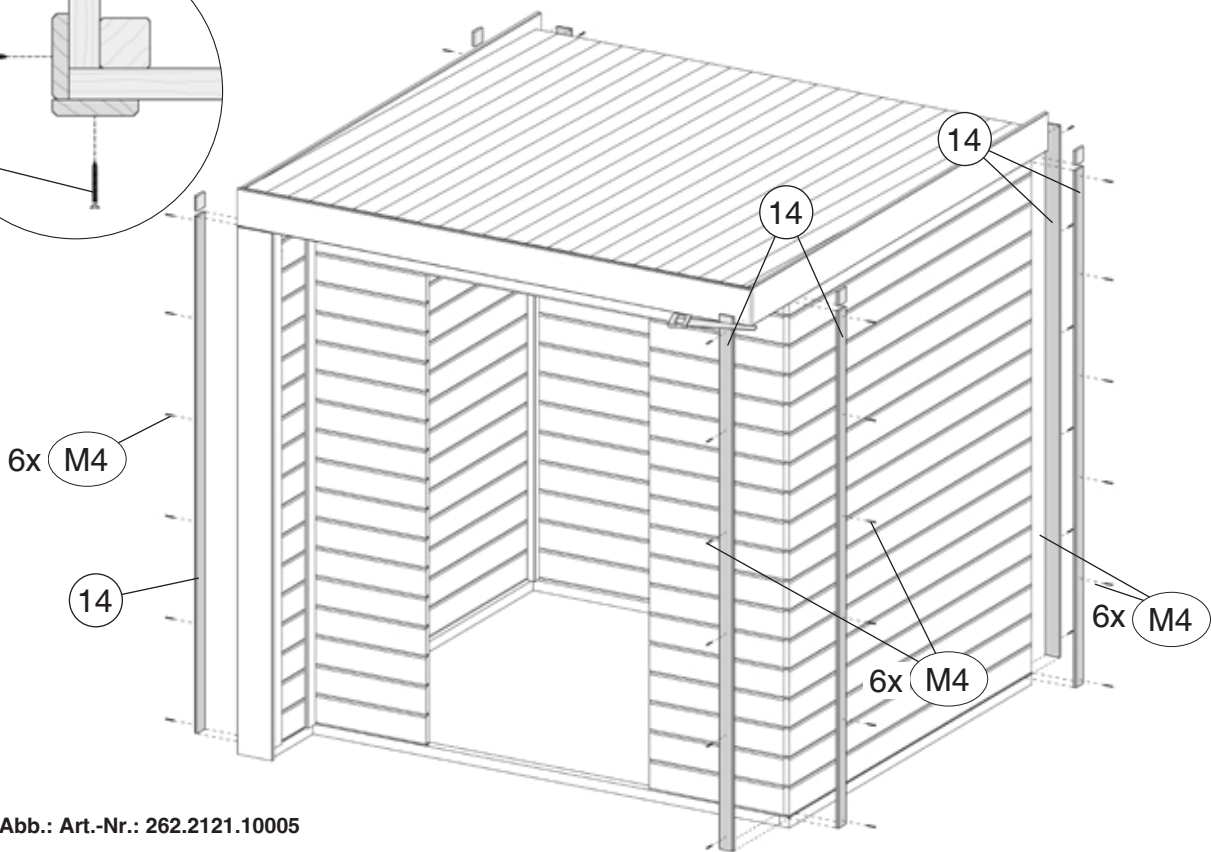
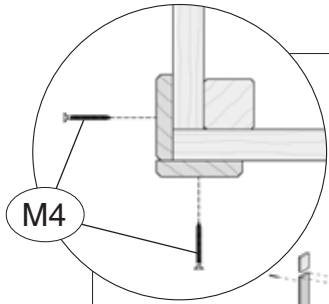

+

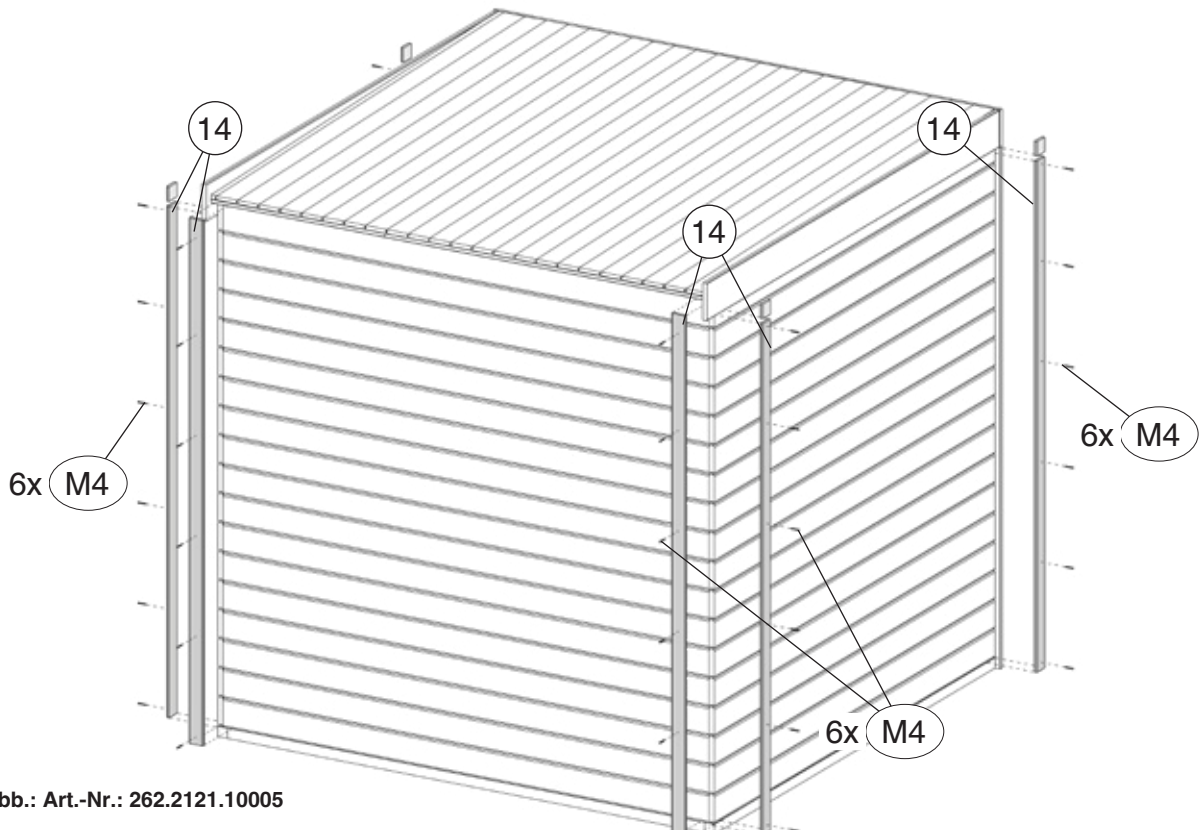
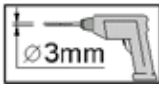
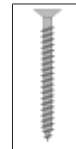
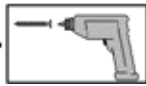

M4 3,5 x 30



Abb.: Art.-Nr.: 262.2121.10005

23



+

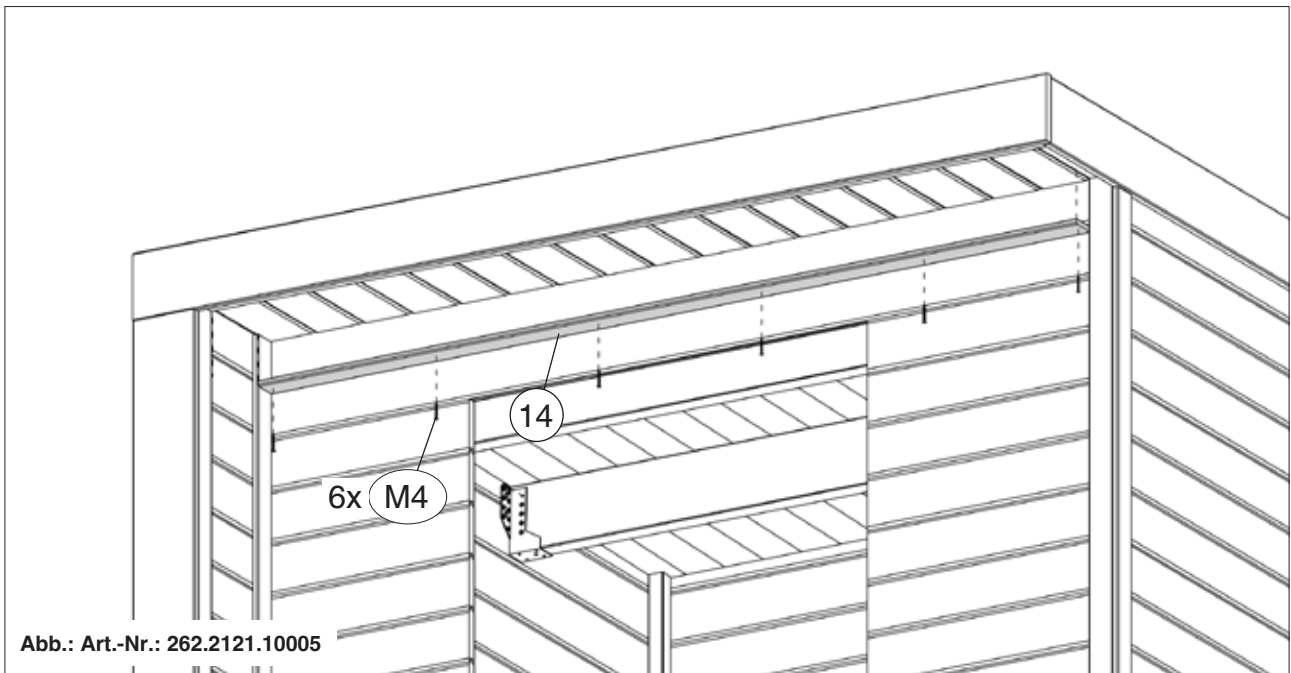

262.2121.1x001x
262.2121.1x000x

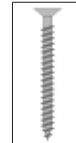

M3 4,0 x 40



Abb.: Art.-Nr.: 262.2121.10005

23.1



24

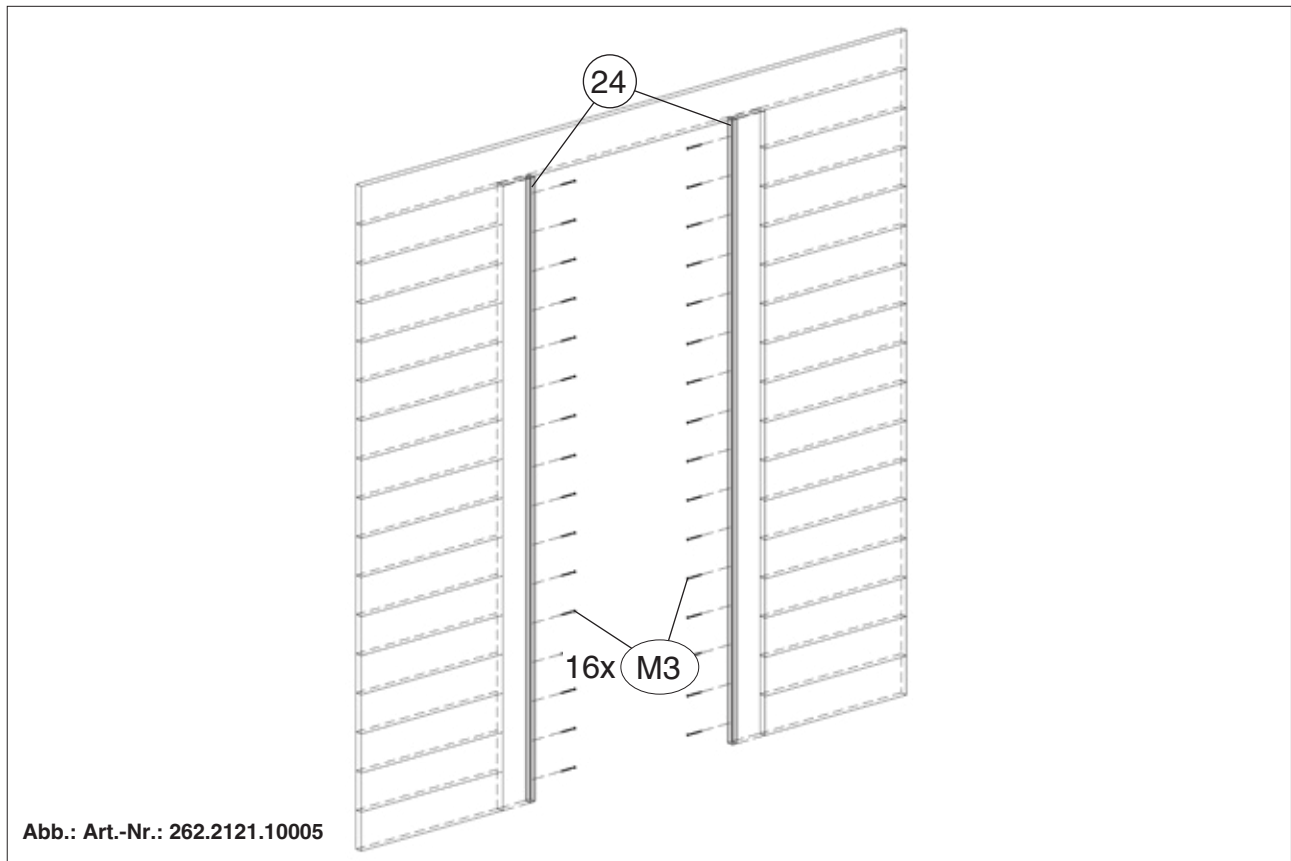
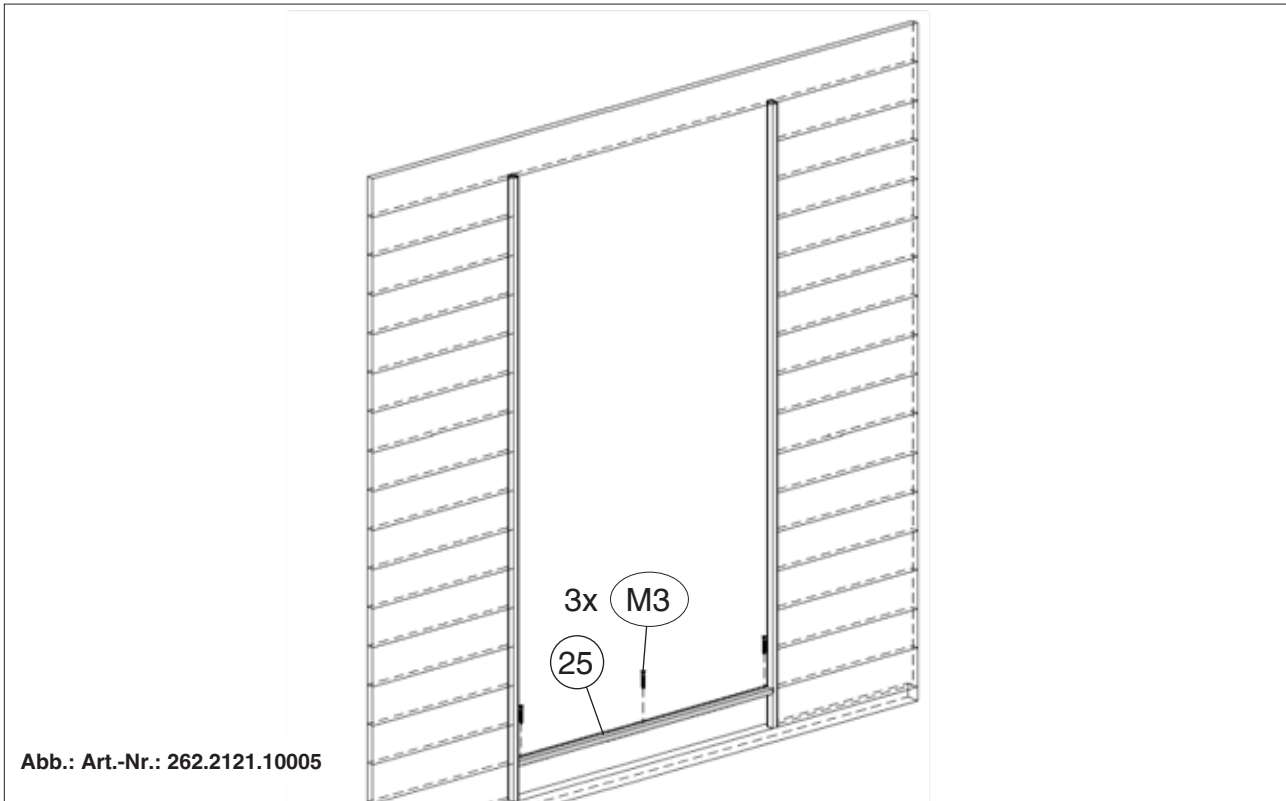
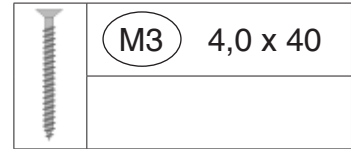
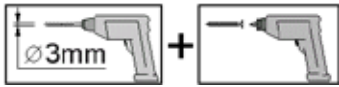
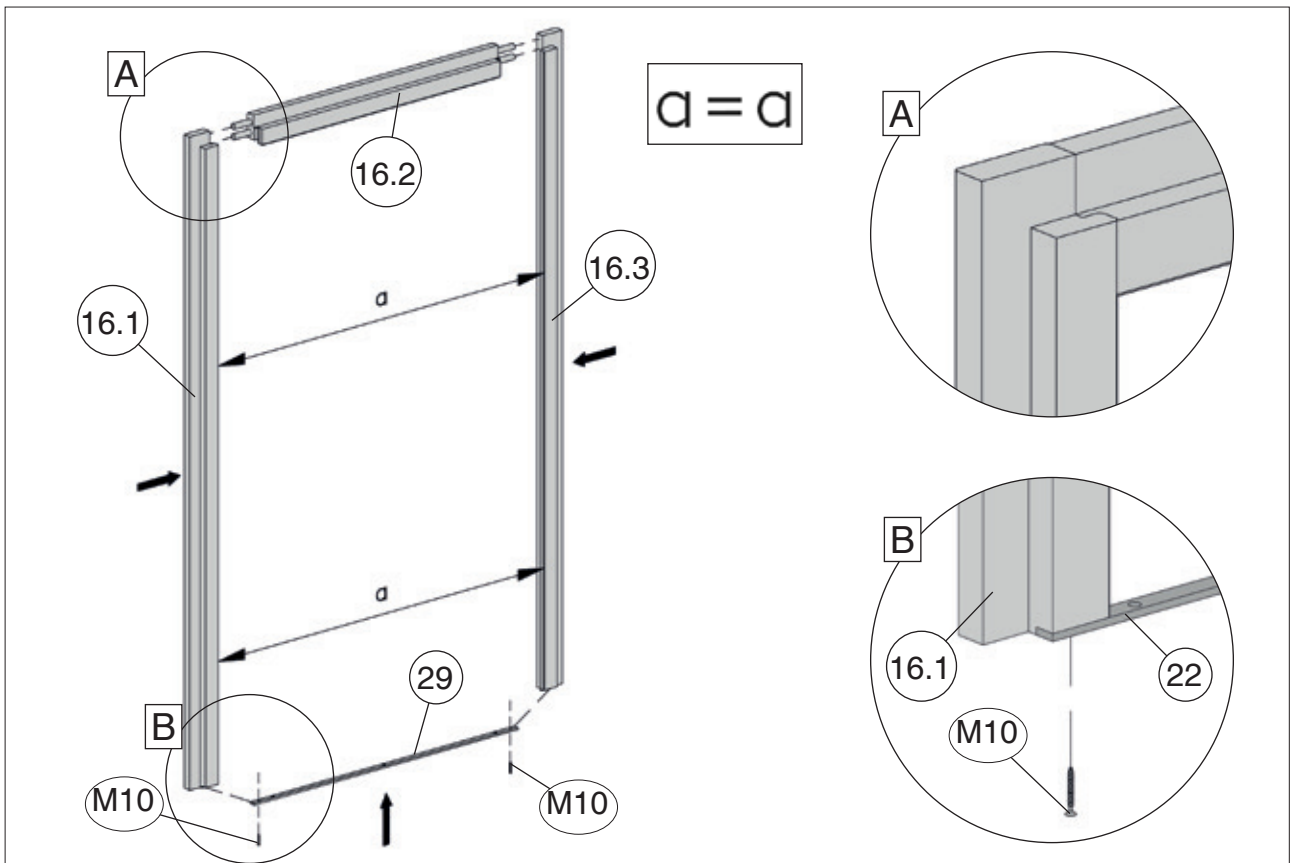
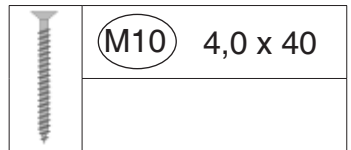

25

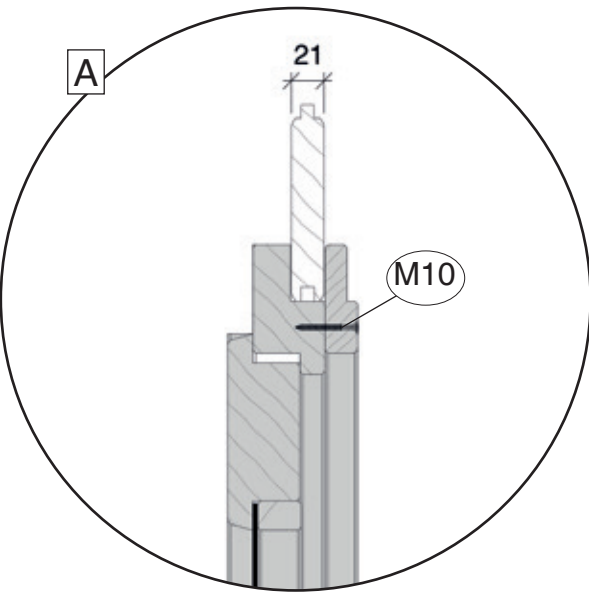
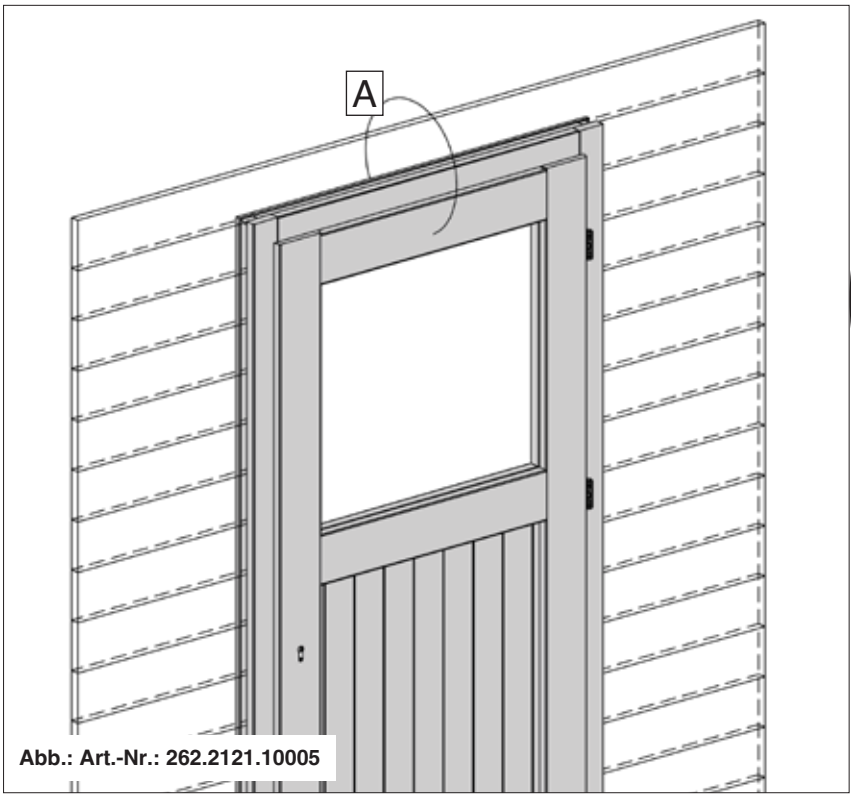
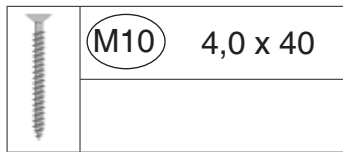
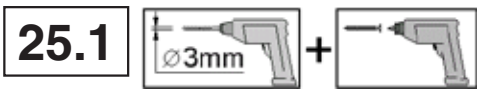
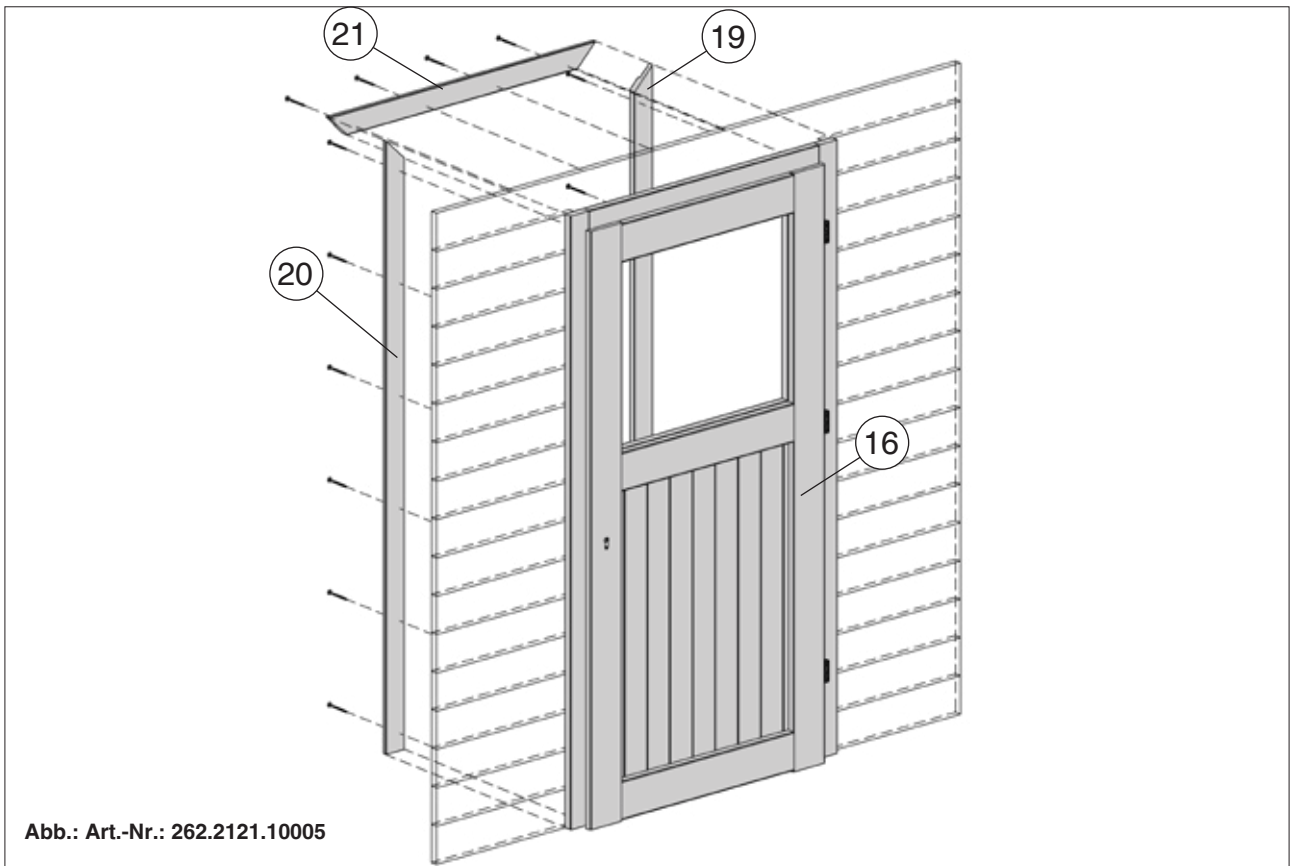

26

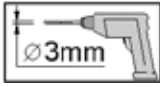

+

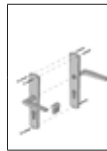
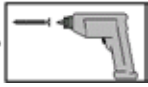

M13



M11

1,6 x 30

M12



Abb.: Art.-Nr.: 262.2121.10005

1.



2.

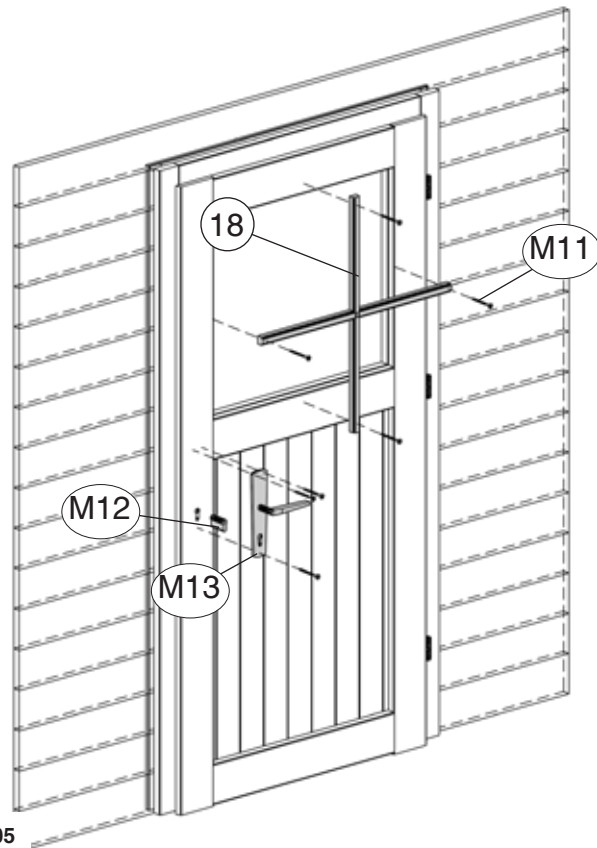
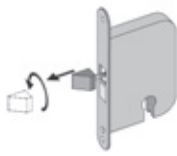

3.



27

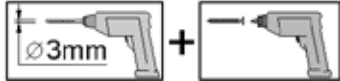

	M10 4,0 x 40
---	--------------



Abb.: Art.-Nr.: 262.2121.10005

27.1

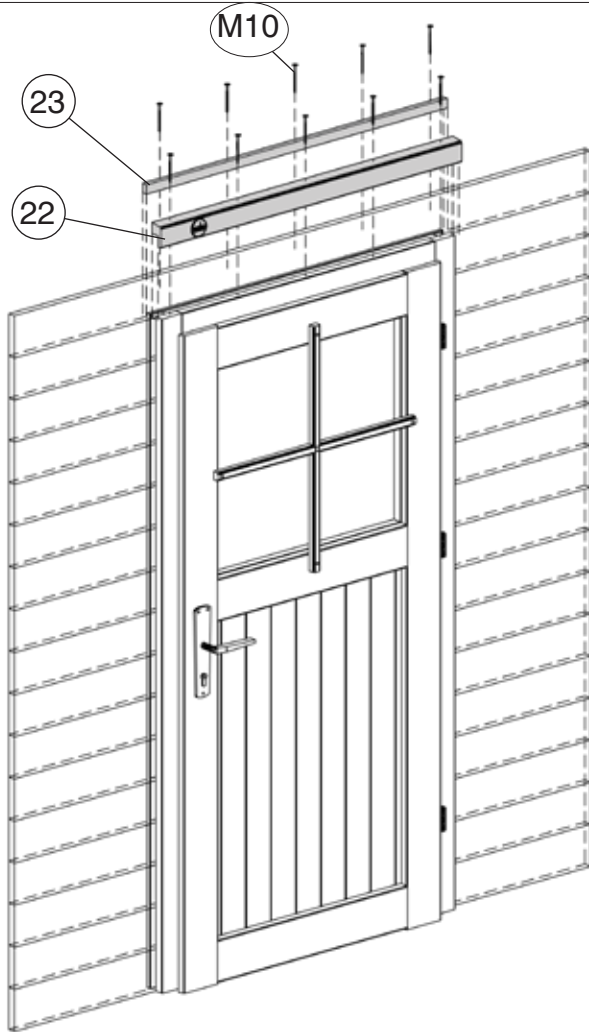

Abb.: Art.-Nr.: 262.2121.10005

23



262.2121.1x002x
262.2121.1x003x

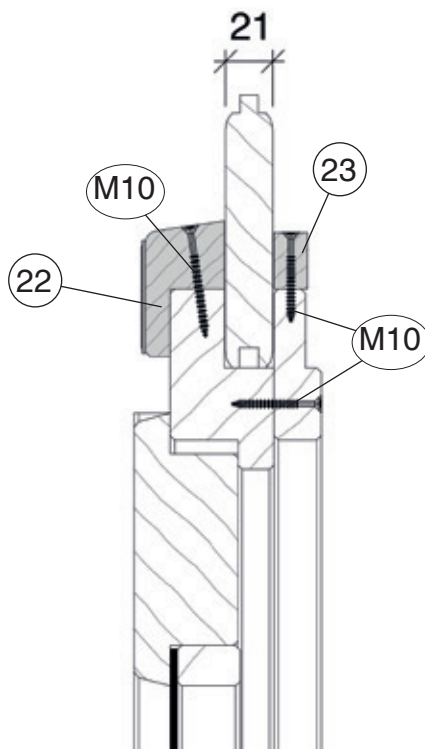
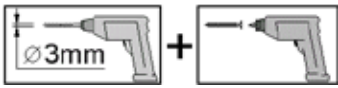
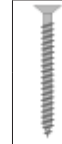

M3 4,0 x 40



Abb.: Art.-Nr.: 262.2121.10025

23.1



M3 4,0 x 40

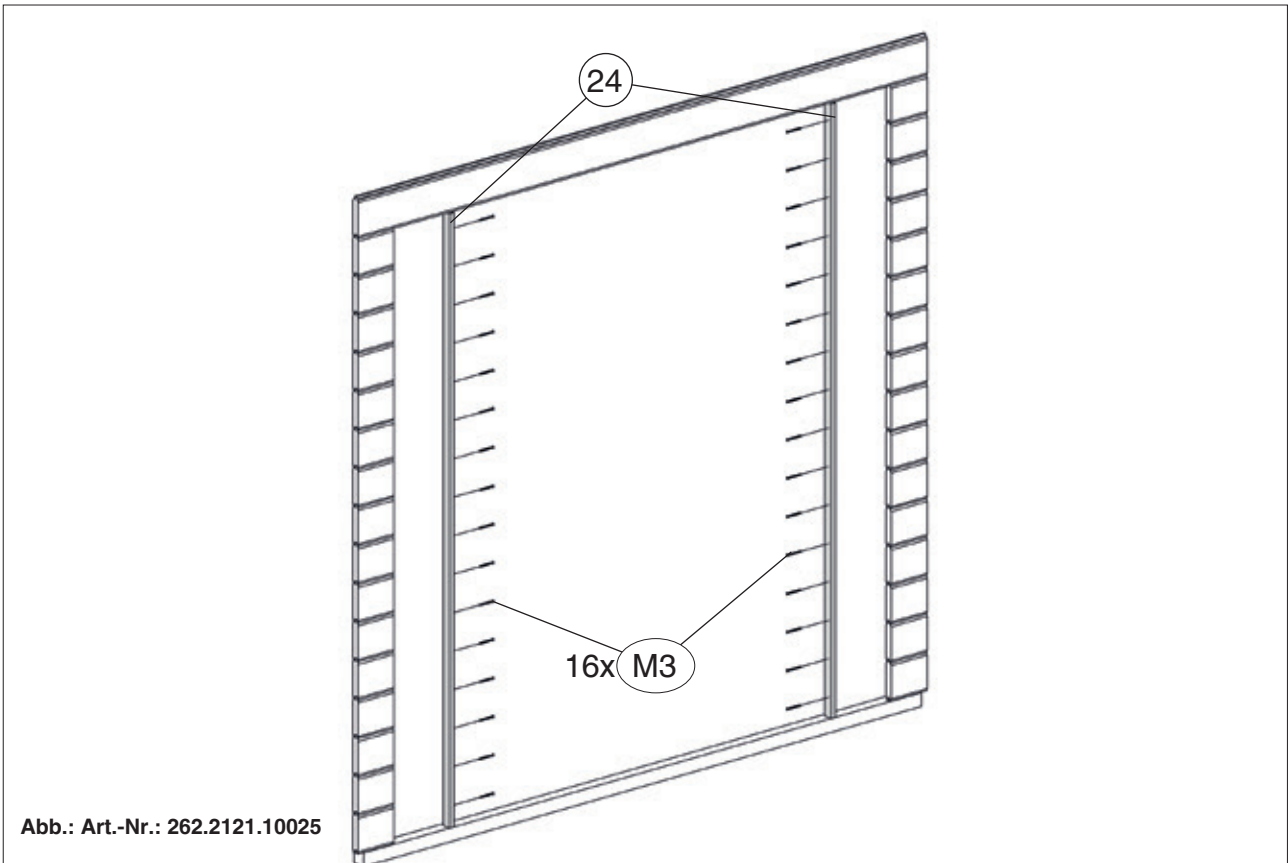
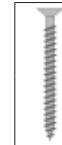
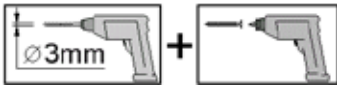



Abb.: Art.-Nr.: 262.2121.10025

	M15 4,0 x 40

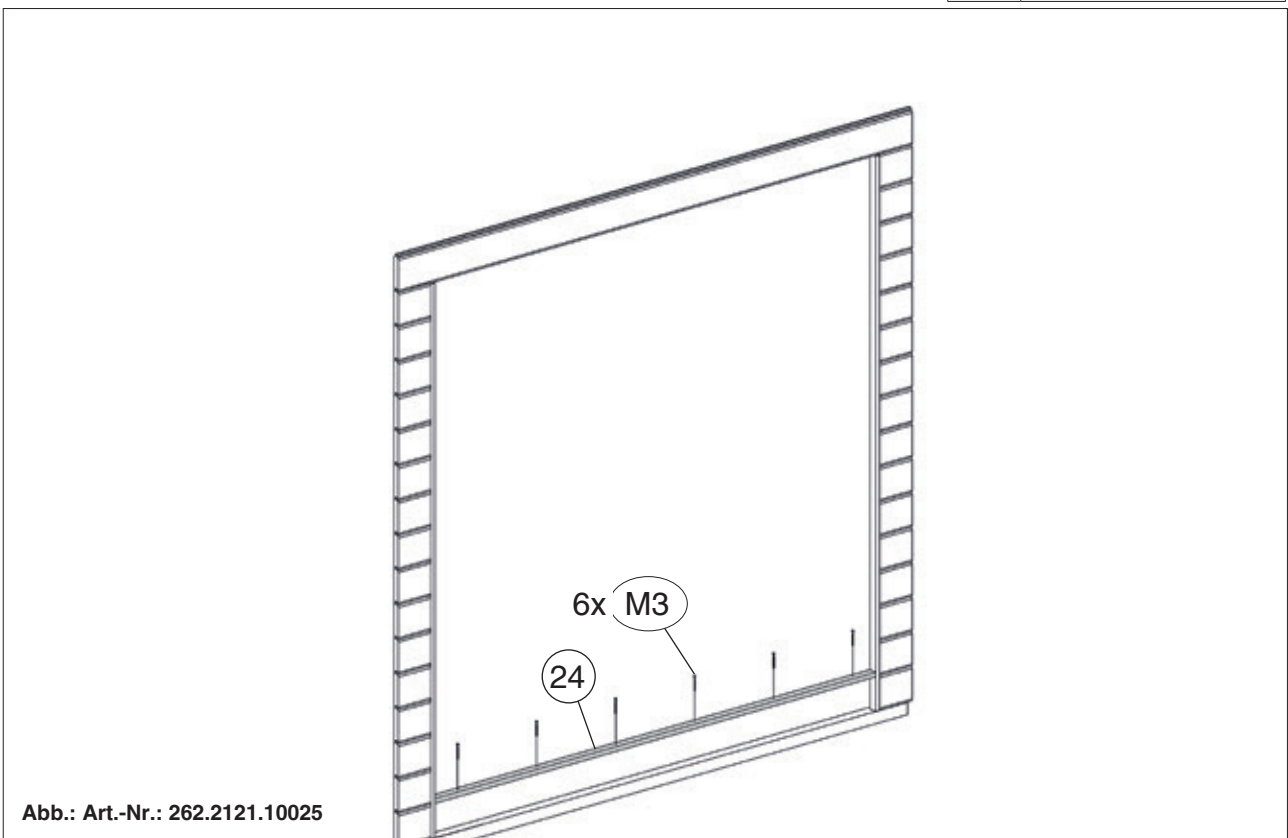

25

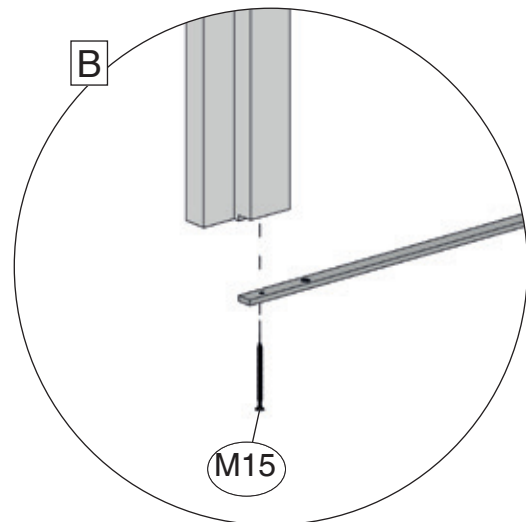
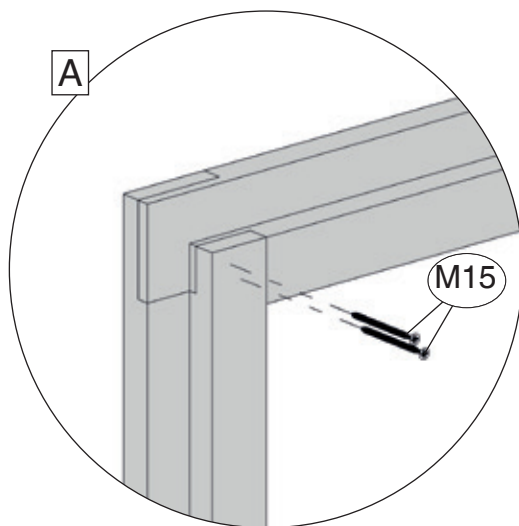
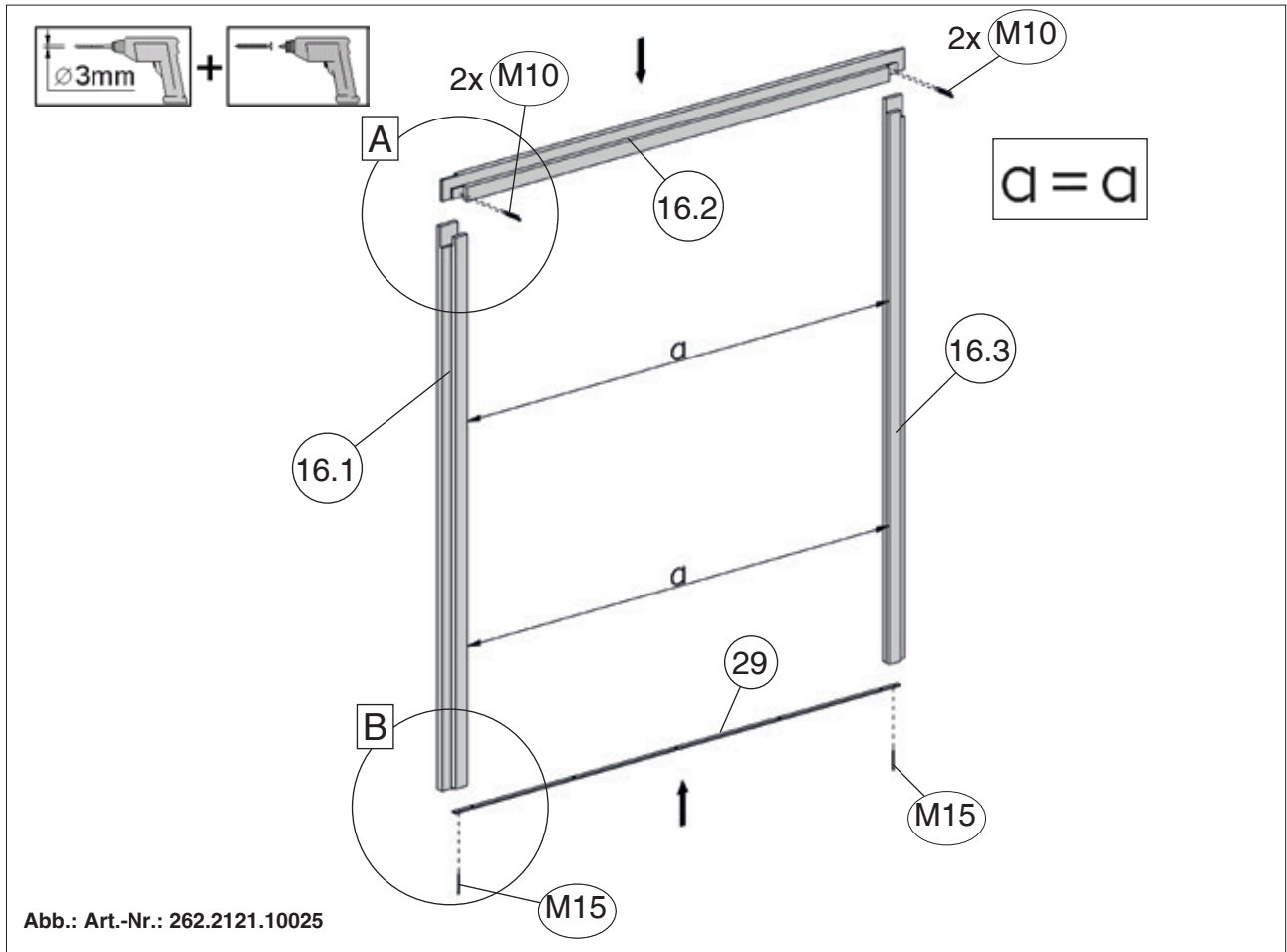
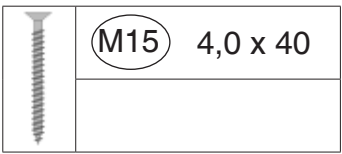
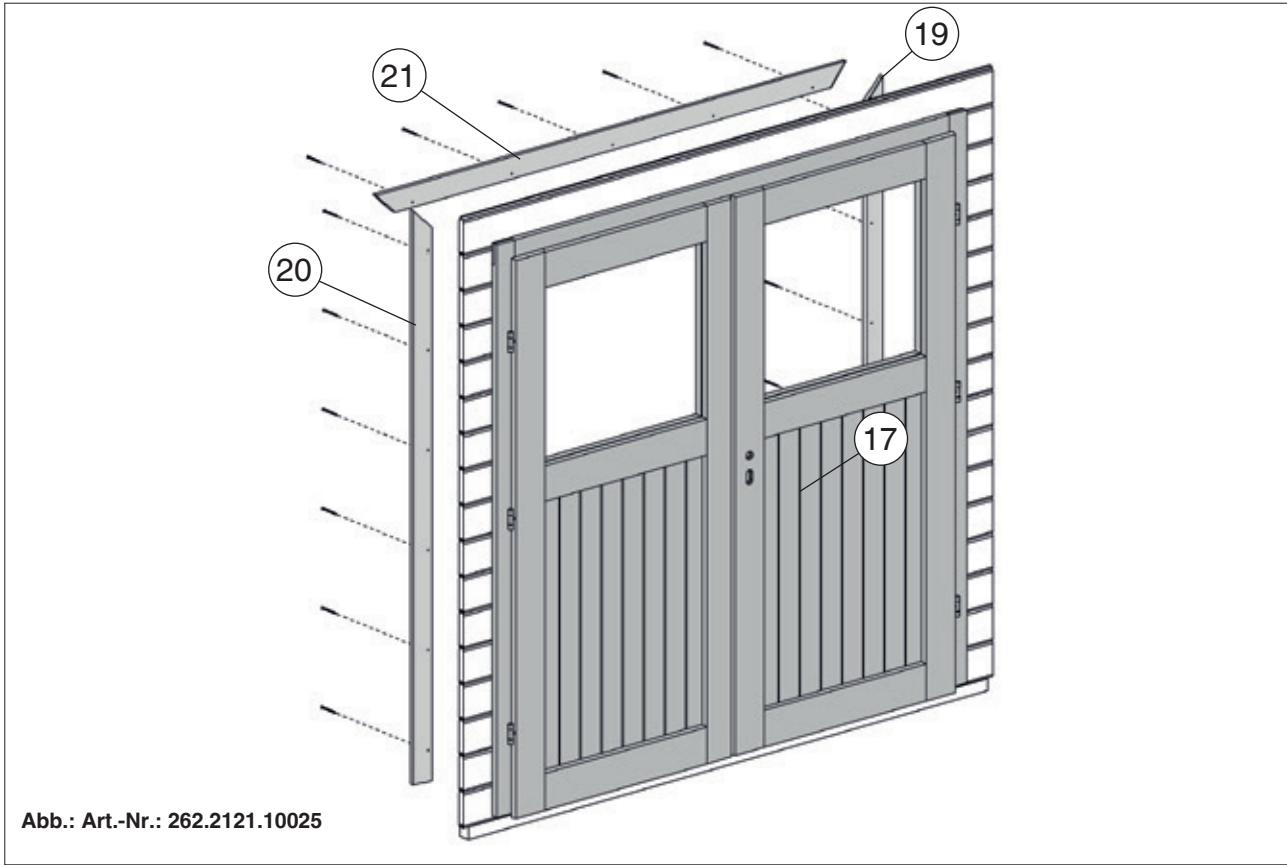
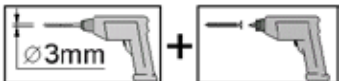

25.1

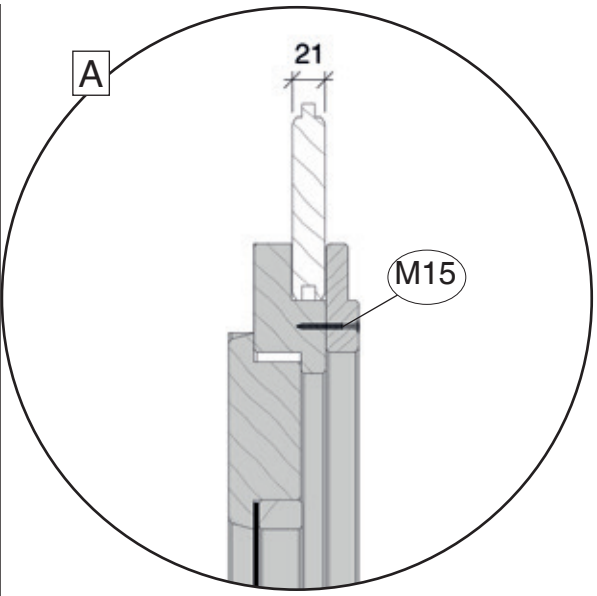
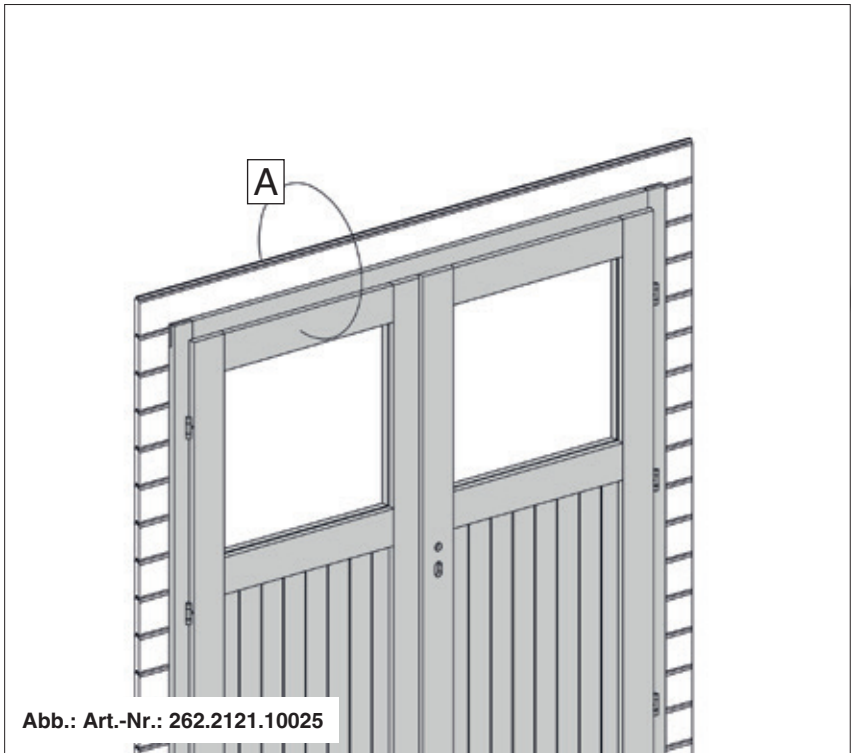

26

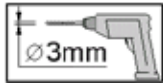

+

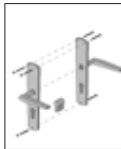
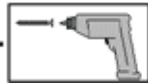

M20



M19 1,6 x 30

M21



Abb.: Art.-Nr.: 262.2121.10025

1.



2.

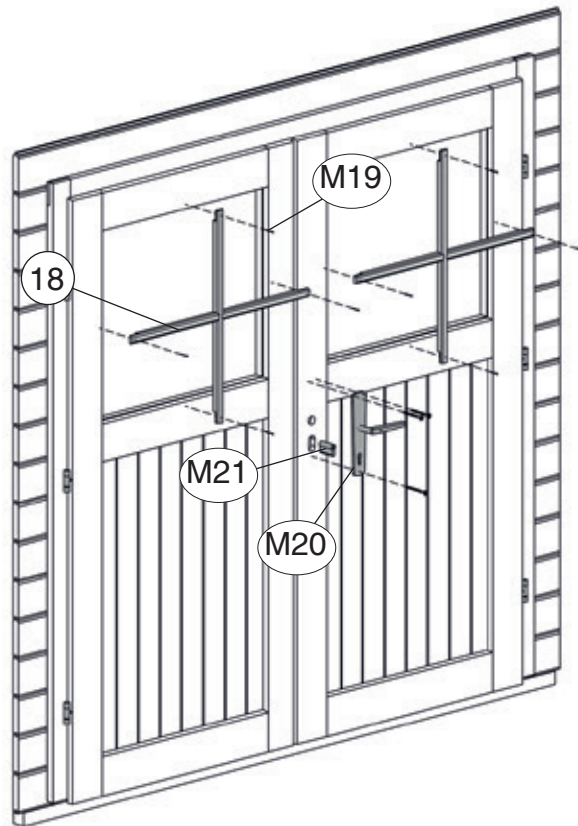
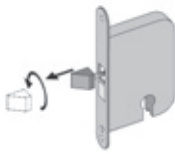

3.



27

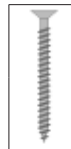
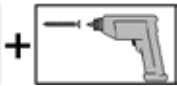
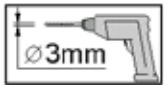

M15 4,0 x 40

M17 3,0 x 30



Abb.: Art.-Nr.: 262.2121.10025

27.1



Abb.: Art.-Nr.: 262.2121.10025

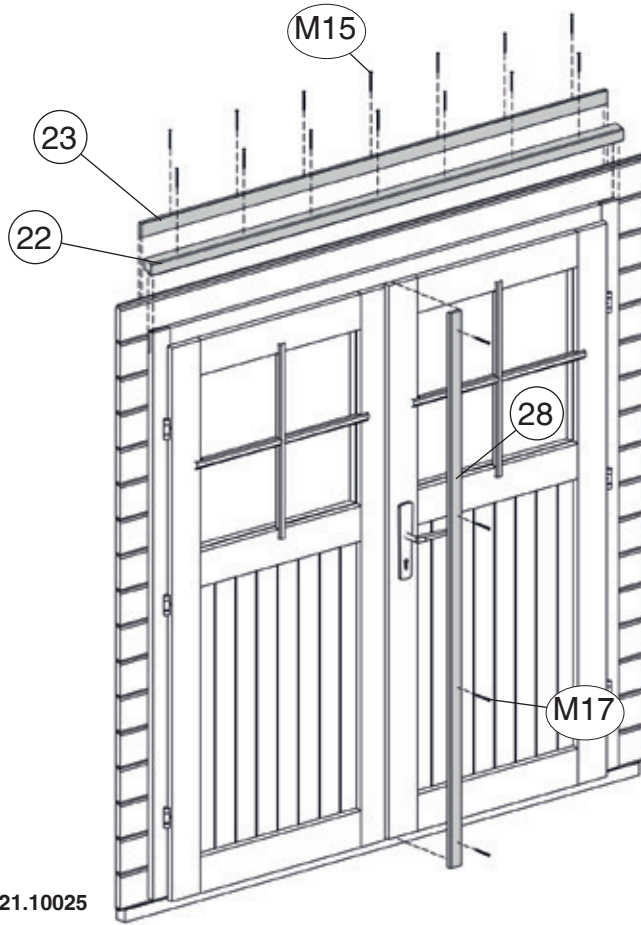

Nachstellen/Justieren der Türflügel

Trotz fachgerechter Montage der Tür lässt es sich nicht umgehen, das Sie, besonders in der Anfangszeit und bei extremer Witterungsfolge die Gängigkeit der Türflügel regelmäßig prüfen und nachstellen.

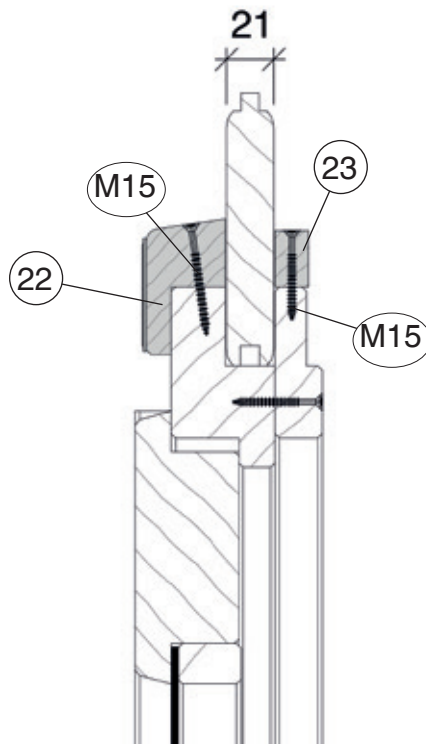
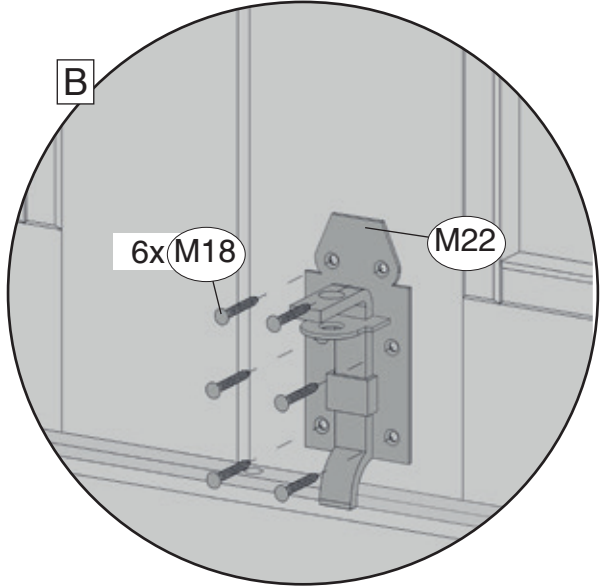
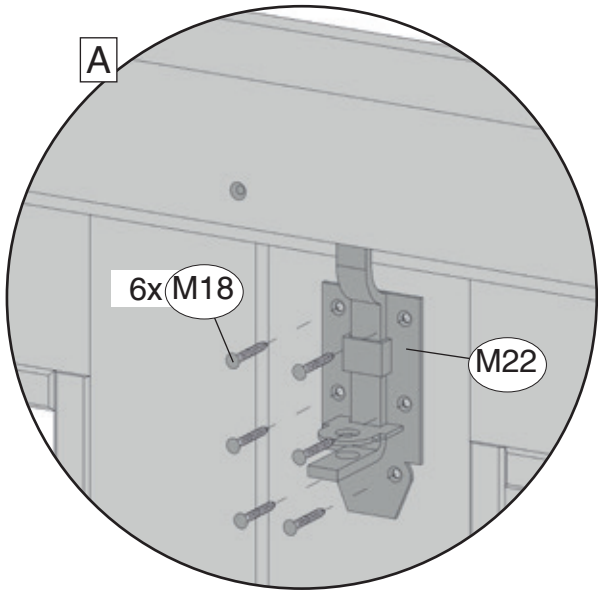
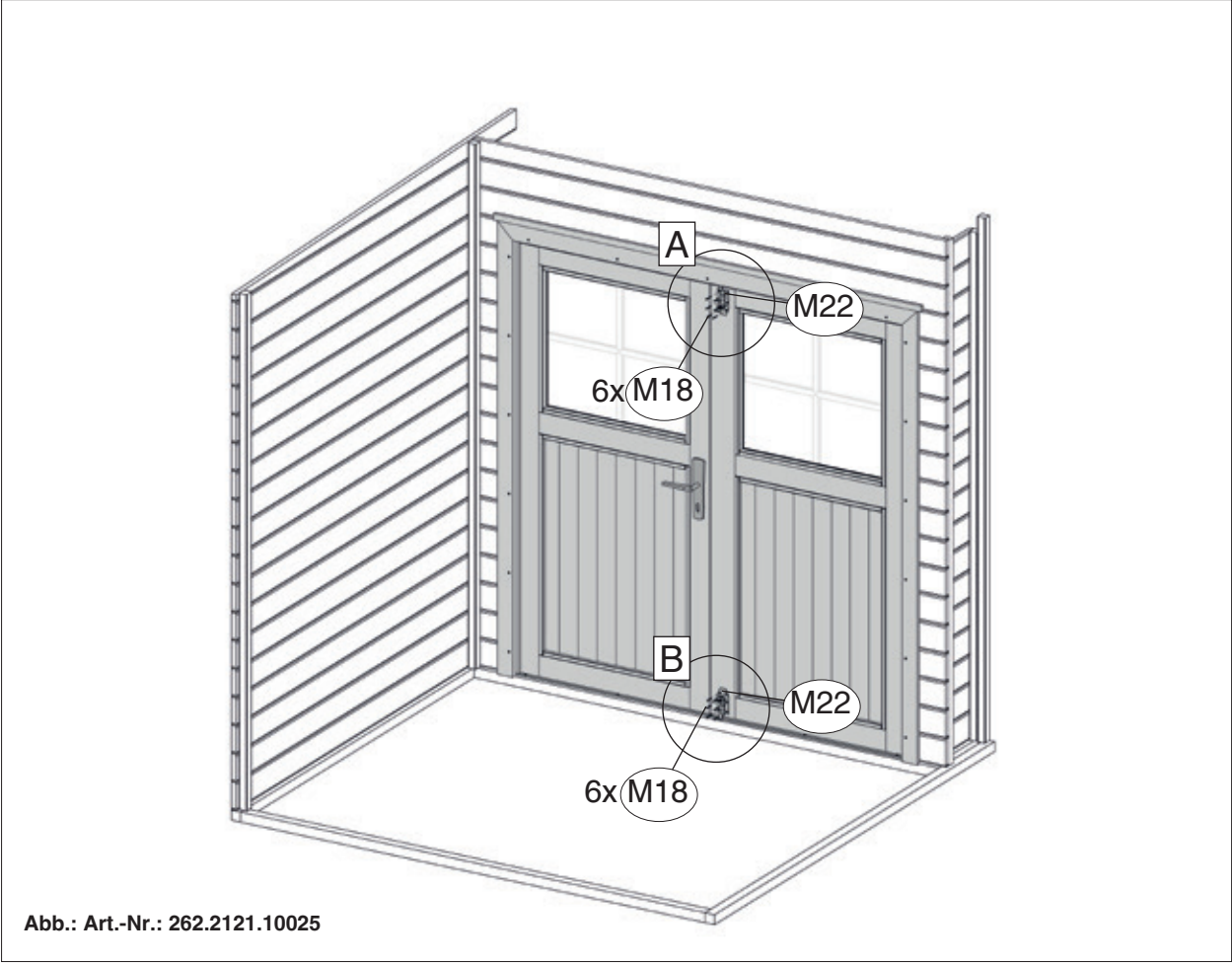
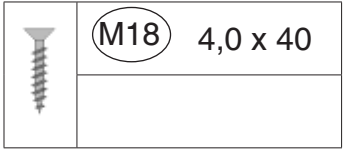
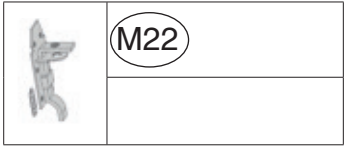
Durch Herein- und Herausschrauben der Scharnierbänder ist ein Nachjustieren der Türflügel möglich. Holz ist ein Naturprodukt, daher ist leichter Verzug bei Massivholz-Türblättern leider nie ganz auszuschließen.





Abb.: Art.-Nr.: 262.2121.10005

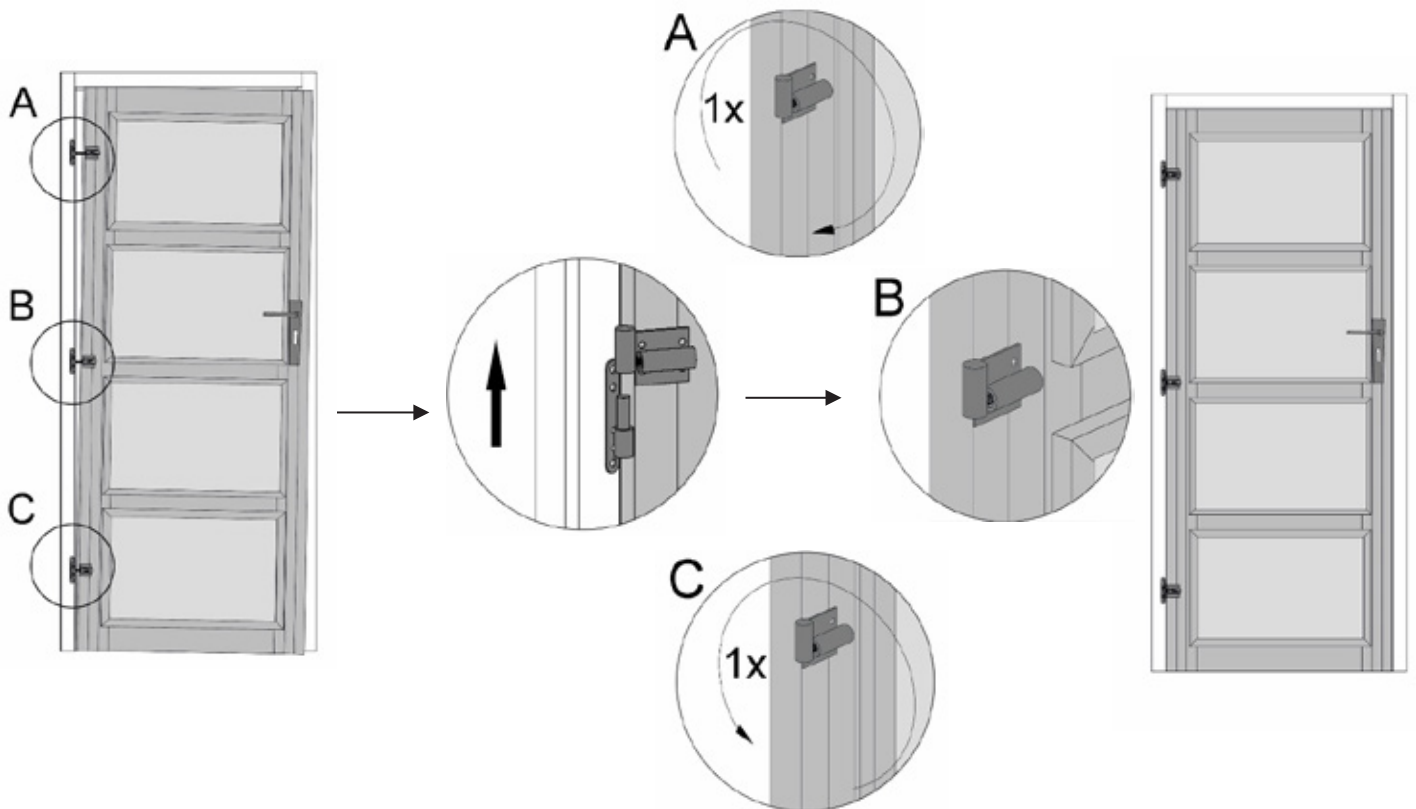
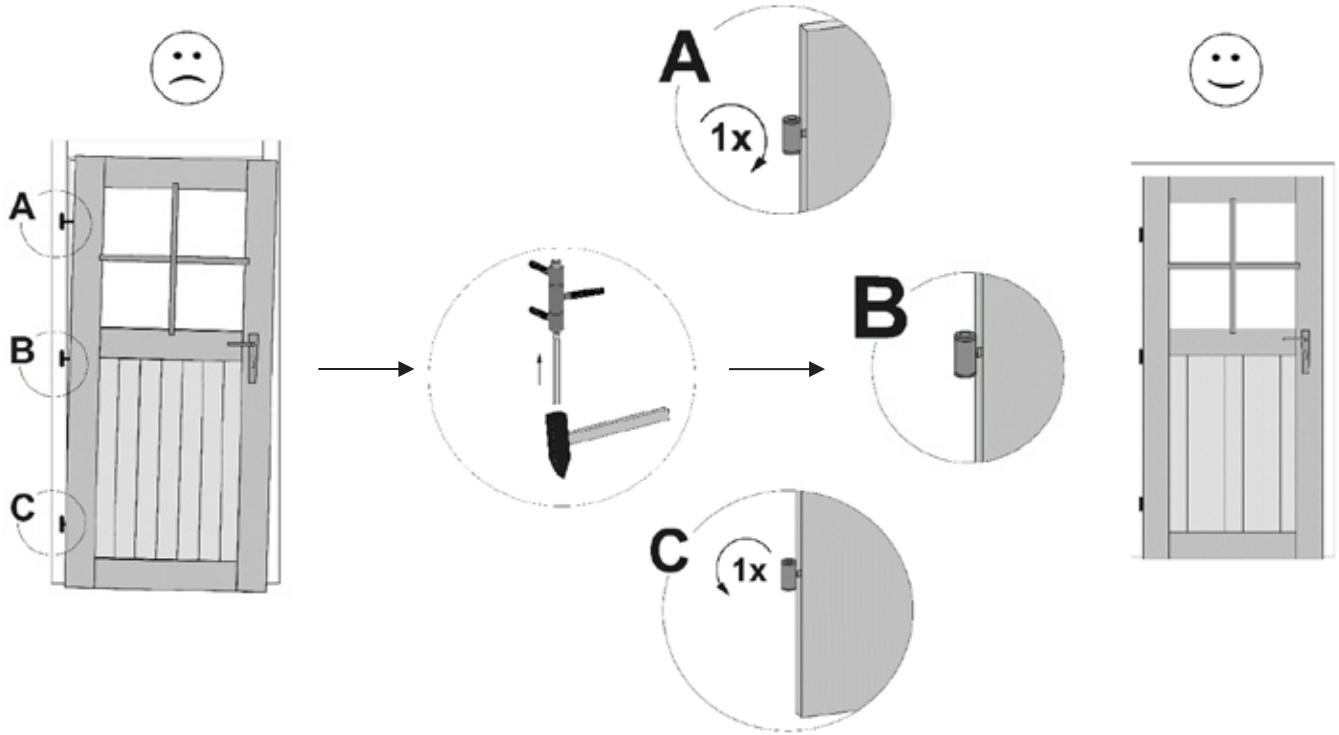

Abb.: Art.-Nr.: 262.2121.10025

Kennen Sie schon die WEKA- Wellnesswelt?



Jetzt
scannen
und unsere
**Saunen &
Infrarotkabinen**
entdecken!

www.weka-holzbau.com

weka

WEKA Holzbau GmbH

Johannesstr. 16, 17034 Neubrandenburg

Tel.: +49 (0)395 42908-0

Fax: +49 (0)395 42908-83

Mail: info@weka-holzbau.com

Web: www.weka-holzbau.com

MA Art.-Nr.: 800.0286.17.72